

MECHANICAL, ELECTRICAL,
AND PLUMBING REVIEWS
WILL BE DEFERRED TO
FIELD INSPECTORS

Permit # **1824-0289**
REVIEWED FOR CODE COMPLIANCE
LONGBOAT KEY BUILDING DEPT.
APR 03 2024
APPROVED
Reviewer: *Jamethon*

RECEIVED
MAR 27 2024
TOWN OF LONGBOAT KEY
Planning, Zoning & Building

EXISTING FLOOR PLAN SHOWING DEMOLITION 1/4"=1'-0"

- INDICATES WALLS OR PORTIONS OF NON-BEARING WALLS TO BE REMOVED
- INDICATES PLUMBING STACK LOCATIONS IN WALLS.
- INDICATES EXISTING SPRINKLER HEADS

COMPLIANCE STATEMENT:
THESE PLANS ARE IN COMPLIANCE WITH:
2023 FLORIDA BUILDING CODE, 8TH EDITION
2023 FLORIDA BUILDING CODE, EXISTING BUILDING
2023 FLORIDA BUILDING CODE, PLUMBING
2023 FLORIDA BUILDING CODE, MECHANICAL
2023 FLORIDA FIRE PREVENTION CODE
2020 NATIONAL ELECTRIC CODE (N.E.C.)

OCEAN BUILDERS
6920 CORRAL GATE LANE
SARASOTA, FLORIDA 34240
PH- (941) 927-2943
FAX- (941) 927-2945

A REMODEL FOR:
THE KING RESIDENCE
THE SANCTUARY, UNIT 806
CITY OF LONGBOAT KEY, FLORIDA

BLDG PERMIT PLANS
FILE
Copy of Record

DATE 2/20/24
SHEET

A-1

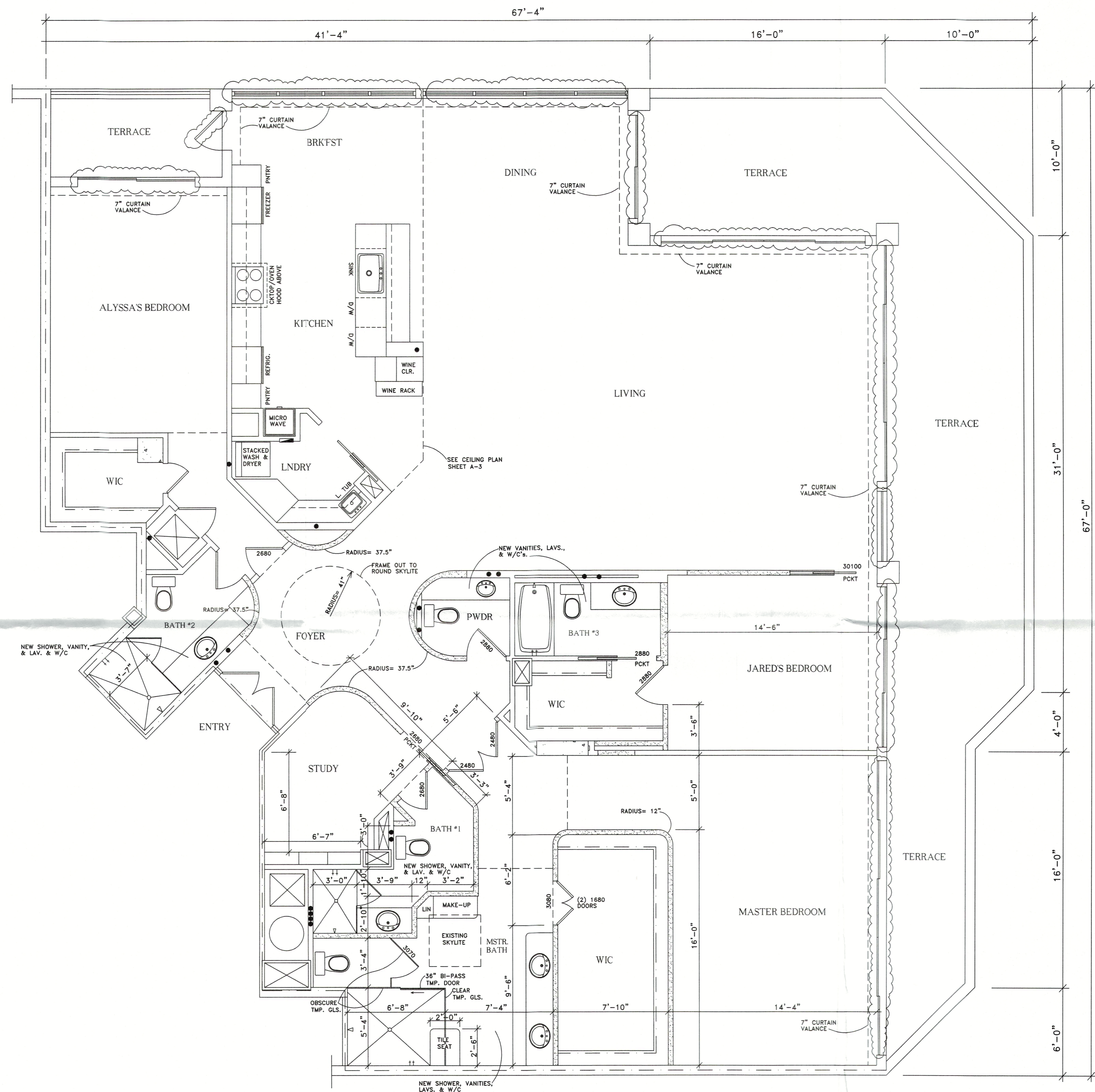

PROPOSED FLOOR PLAN 1/4"=1'-0"

INDICATES NEW WALLS OR PORTIONS OF NEW WALLS

PERMIT #PB24-0289

INDICATES REPLACEMENT OF DOOR, WINDOWS, SLIDING GLASS DOORS WITH SAME-SIZE IMPACT STOREFRONT LAMINATED INSULATED BRONZE TURTLE COMPLIANT GLASS WITH SOLARBAN 70 LOW E.

OCEAN BUILDERS
 6920 CORRAL GATE LANE
 SARASOTA, FLORIDA 34240
 PH- (941) 927-2943
 FAX- (941) 927-2945

A REMODEL FOR:
THE KING RESIDENCE
 THE SANCTUARY, UNIT 806
 CITY OF LONGBOAT KEY, FLORIDA

DATE 7/18/24
 WINDOW & DOOR
 REPLACEMENTS

DATE 5/16/24

SHEET

RECEIVED
 AUG 14 2024
 TOWN OF LONGBOAT KEY
 Planning, Zoning & Building
 BLDG PERMIT PLANS
 FILE
 Copy of Record

A-2

1-1/2"x1-1/2"x12" STEEL ANGLE @ 60° DC. ATTACH TO SLAB W/ (3) 3/4" DRIVEPINS EA. ANGLE

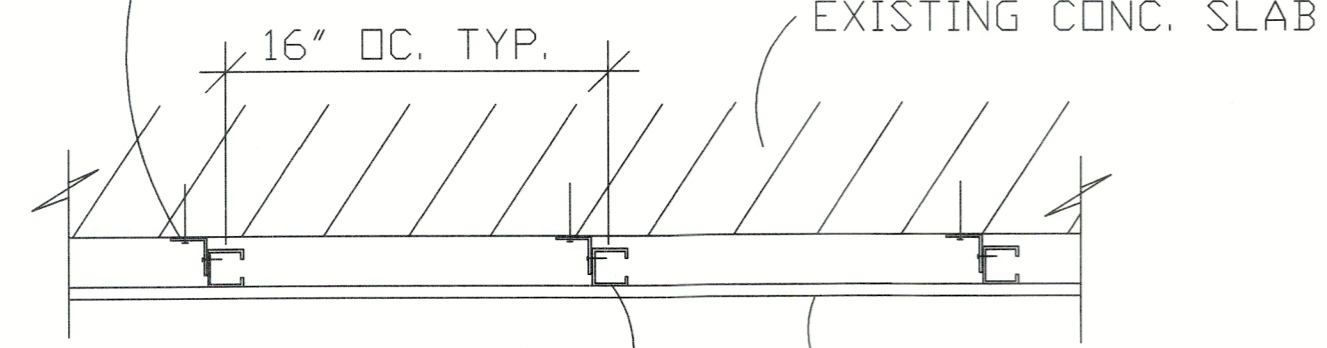

1-5/8"x1-5/8" STEEL STUD ATTACH TO ANGLE W/ (2) #6, 7/16" FRAMING SCREWS @ 60° DC.

DROPPED CEILING DETAIL 1-1/2"=1'-0"

EXISTING EXTERIOR WALL
EXISTING CONC. BEAM
1-1/2"x1-1/2"x12" STEEL ANGLE @ 60° DC. ATTACH TO SLAB W/ (3) 3/4" DRIVEPINS EA. ANGLE
EXISTING CONC. SLAB

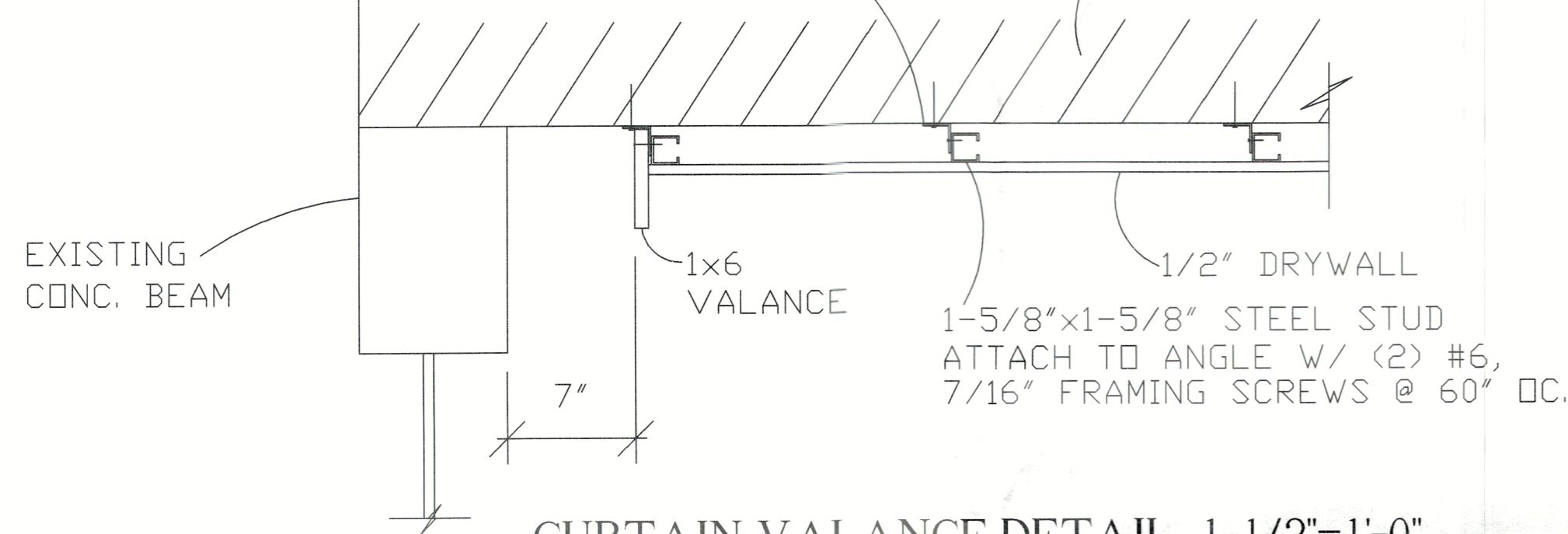

CURTAIN VALANCE DETAIL 1-1/2"=1'-0"

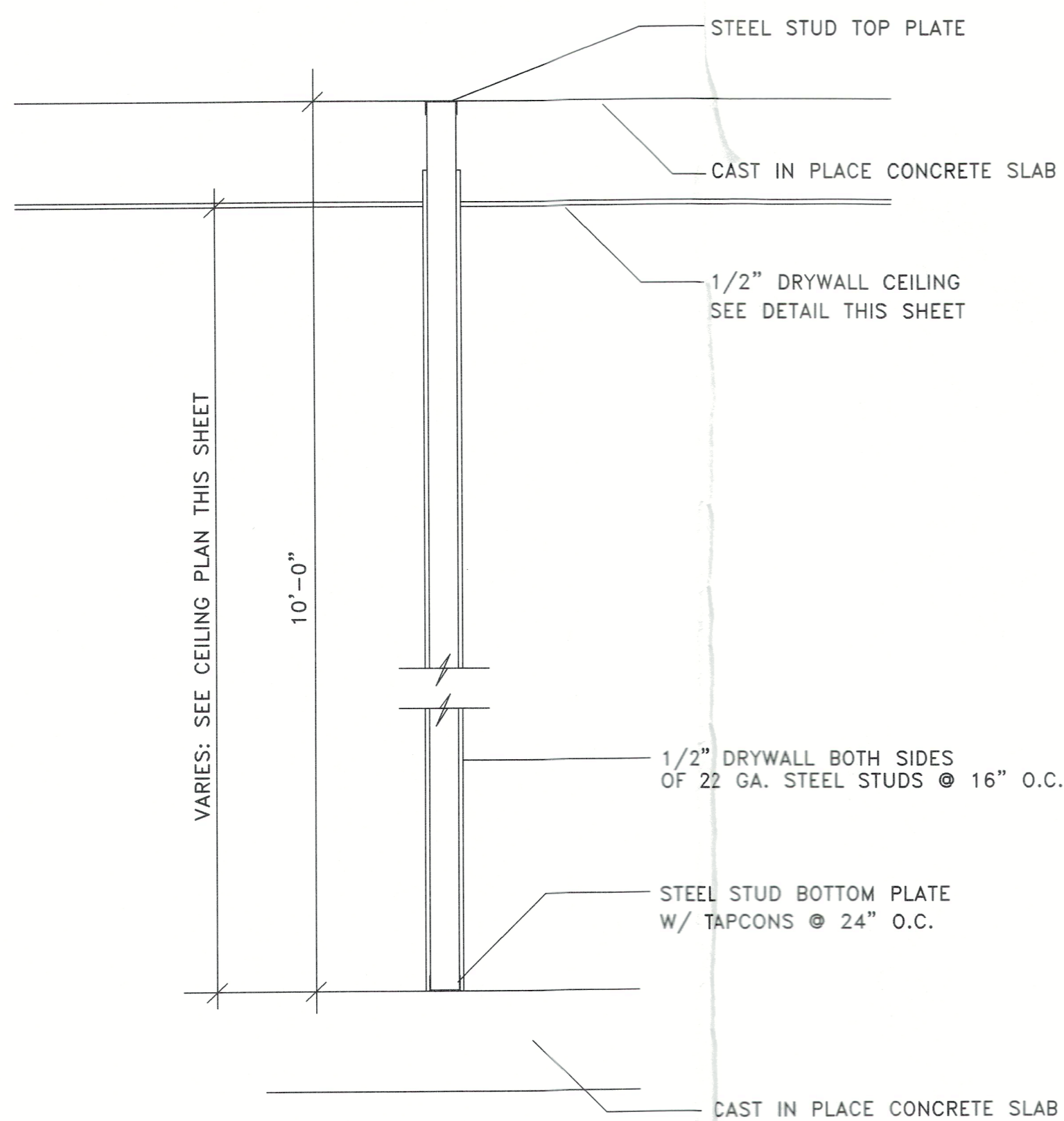

TYPICAL INTERIOR NON-BEARING WALL
3/4" = 1'-0"

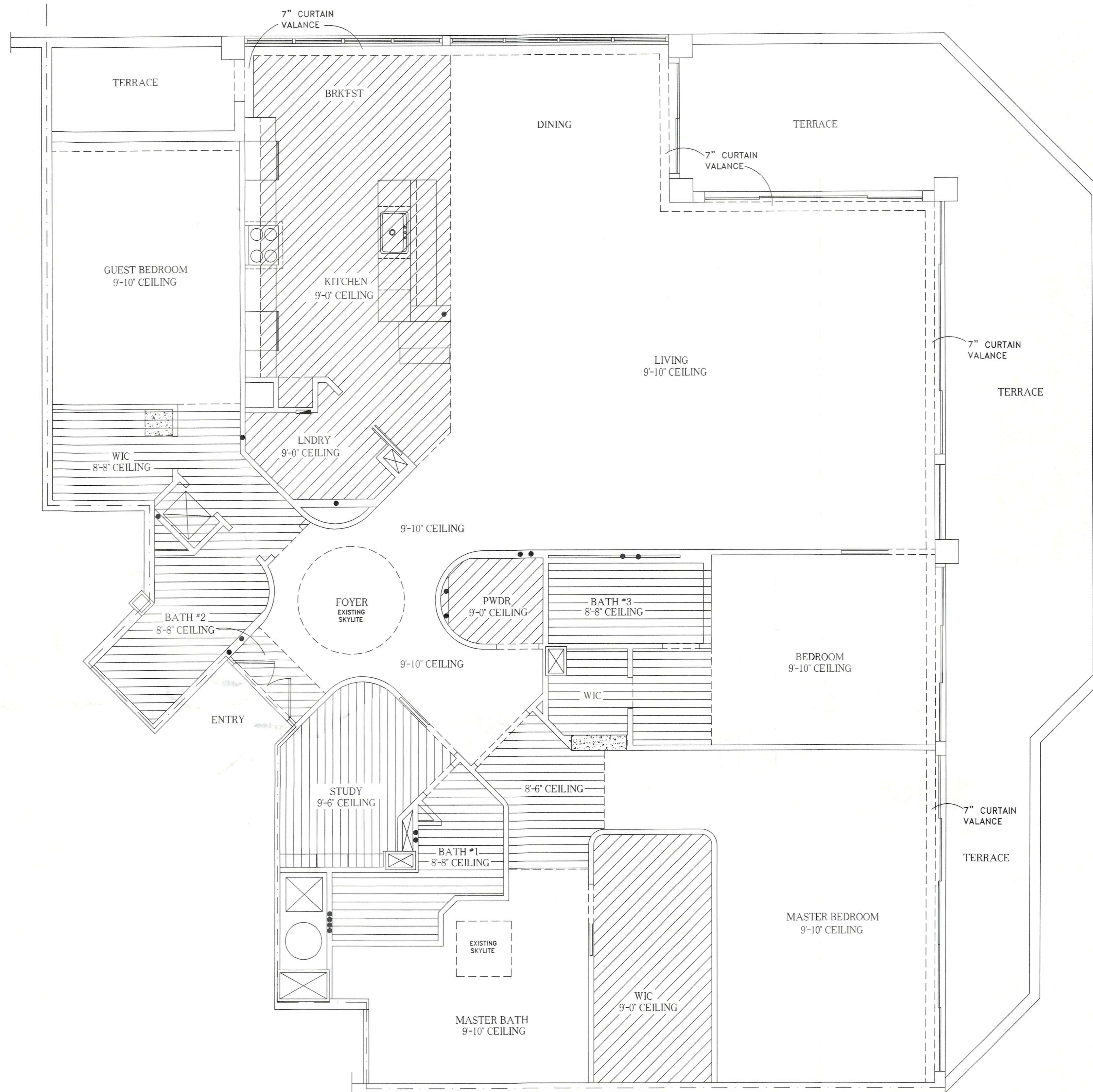

PLAN SHOWING FINISHED CEILING HEIGHTS 1/4"=1'-0"

- INDICATES 9'-0" CEILING
- INDICATES 9'-10" CEILING
- INDICATES 8'-8" CEILING
- INDICATES 9'-6" CEILING

OCEAN BUILDERS
6920 CORRAL GATE LANE
SARASOTA, FLORIDA 34240
PH- (941) 927-2943
FAX- (941) 927-2945

A REMODEL FOR:
THE KING RESIDENCE
THE SANCTUARY, UNIT 806
CITY OF LONGBOAT KEY, FLORIDA

BLDG PERMIT PLANS
FILE
Copy of Record

DATE 2/20/24
SHEET

A-3

RECEIVED
MAR 27 2024
TOWN OF LONGBOAT KEY
Planning, Zoning & Building



ELECTRICAL LEGEND

- FLUORESCENT FIXTURE
- R RECESSED CEILING FIXTURE (4")
- WALL HUNG LIGHT FIXTURE
- CEILING HUNG LIGHT FIXTURE
- ⊕ DUPLEX OUTLET
- ⊕ 220 VOLT OUTLET
- ⊕ JB JUNCTION BOX
- ⊕ WP GFI WATERPROOF OUTLET
- ▼ PHONE
- ⊕ R VP RECESSED, VAPOR PROOF LIGHT
- WRAPPED FLUORESCENT LIGHT
- ⊕ COMBINATION EXHAUST FAN/LIGHT
- ⊕ SPECIAL OUTLET
- ⊕ EXHAUST FAN
- ⊕ TV CABLE TV OUTLET
- ⊕ CEILING FAN
- ⊕ SD SMOKE DETECTOR
- ⊕ MD MOTION DETECTOR
- ⊕ CS COMBINATION SMOKE/CARBON MONOXIDE DETECTOR
- PENDANT LIGHT

ELECTRICAL NOTES:

- 1.) ALL RECESS CANS TO BE COMPACT FLUORESCENTS OR LED. A MIN. OF 75% OF THE LAMPS IN PERMANENTLY INSTALLED LIGHTING FIXTURES SHALL BE HIGH-EFFICACY LAMPS OR A MIN. OF 75% OF THE PERMANENTLY INSTALLED LIGHTING SHALL CONTAIN ONLY HIGH EFFICACY LAMPS.
- 2.) ALL OUTLETS NOT REQUIRED TO BE GFI PROTECTED SHALL BE ARC-FAULT AND TAMPER-PROOF RECEPTACLES.
- 3.) ALL SMOKE AND CARBON MONOXIDE DETECTORS SHALL BE HARD-WIRED AND INTERCONNECTED.
- 4.) ELECTRICAL SHOWN IS IN REMODELED AREAS ONLY. ANY ADDITIONAL ELECTRICAL WILL BE INSTALLED PER CODE.
- 5.) ELECTRICAL SHOWN IS IN COMPLIANCE WITH 2020 (N.E.C.) NATIONAL ELECTRIC CODE.

PROPOSED ELECTRICAL PLAN 1/4"=1'-0"

● INDICATES PLUMBING STACK LOCATIONS IN WALLS.

OCEAN BUILDERS
 6920 CORRAL GATE LANE
 SARASOTA, FLORIDA 34240
 PH- (941) 927-2943
 FAX- (941) 927-2945

A REMODEL FOR:
THE KING RESIDENCE
 THE SANCTUARY, UNIT 806
 CITY OF LONGBOAT KEY, FLORIDA

BLDG PERMIT PLANS
 FILE
 Copy of Record

DATE 2/20/24

SHEET

E-1

OF 1

RECEIVED
 MAR 27 2024
 TOWN OF LONGBOAT KEY
 Planning, Zoning & Building