

NOTE:
 1. WHERE SERVICE CONNECTIONS EXCEED 8' IN DEPTH THE SERVICE WYE SHALL BE ENCASED IN CONCRETE.
 2. SEWER SERVICE TO BE STAKED IN THE FIELD BY OR UNDER THE DIRECTION OF A REGISTERED ENGINEER AND/OR LAND SURVEYOR.

SANITARY SEWER SERVICE DETAIL

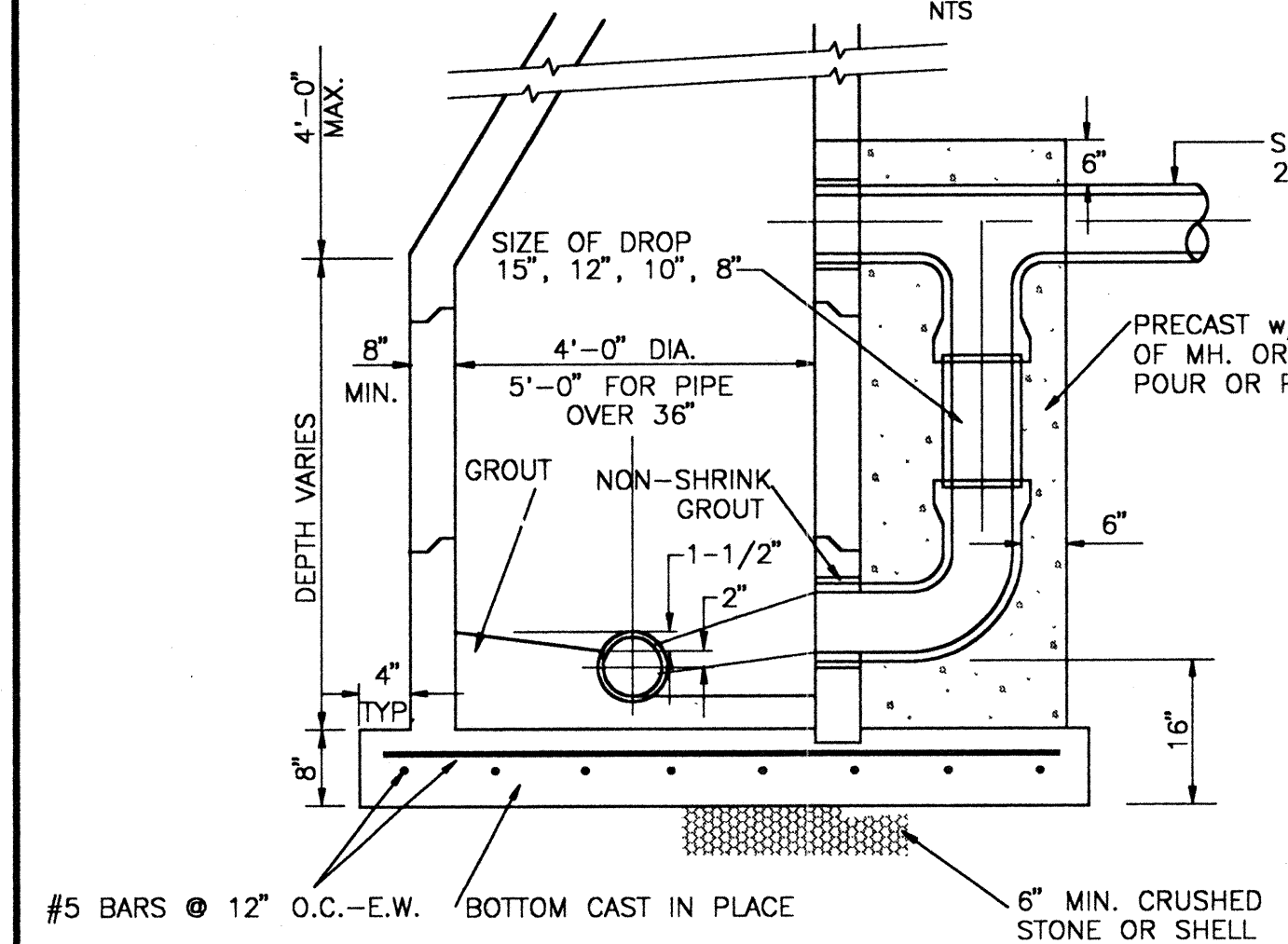

DROP MANHOLE DETAIL

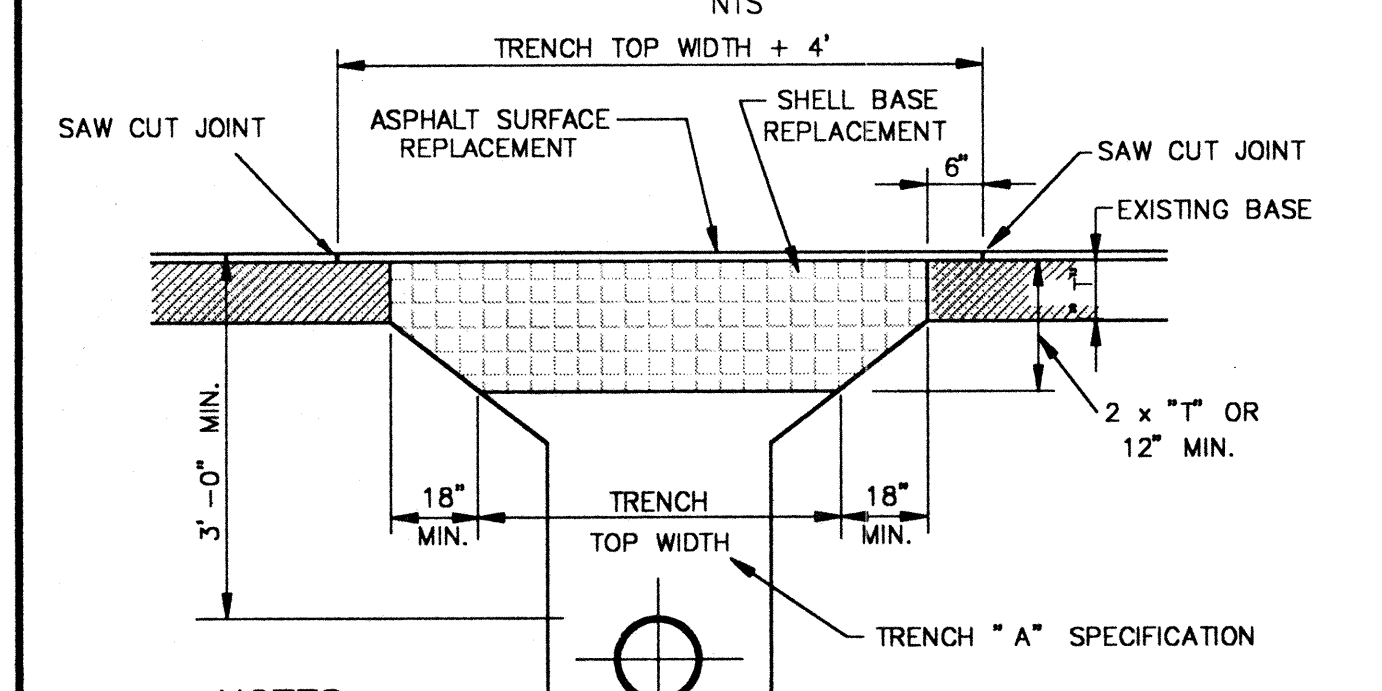

NOTES:
 APPROVED BASE MATERIAL SHALL BE COMPACTED IN 6" LIFTS MAX., TO 98% DENSITY (A.A.S.H.T.O. T-180)
 ASPHALT CONCRETE PAVEMENT JOINTS SHALL BE MECHANICALLY SAWED.
 SURFACE TREATED PAVEMENT JOINTS SHALL BE LAPPED AND FEATHERED.
 SURFACE MATERIAL SHALL BE CONSISTANT WITH EXISTING SURFACE. ASPHALT SHALL BE TYPE I OR II AND EQUAL OR GREATER IN THICKNESS. MINIMUM THICKNESS FOR ASPHALT SHALL BE 1-1/2"
 CONCRETE PAVEMENT JOINTS SHALL BE MECHANICALLY SAWED TO CONFORM WITH ADJACENT PAVEMENT.

PAVEMENT RESTORATION DETAIL

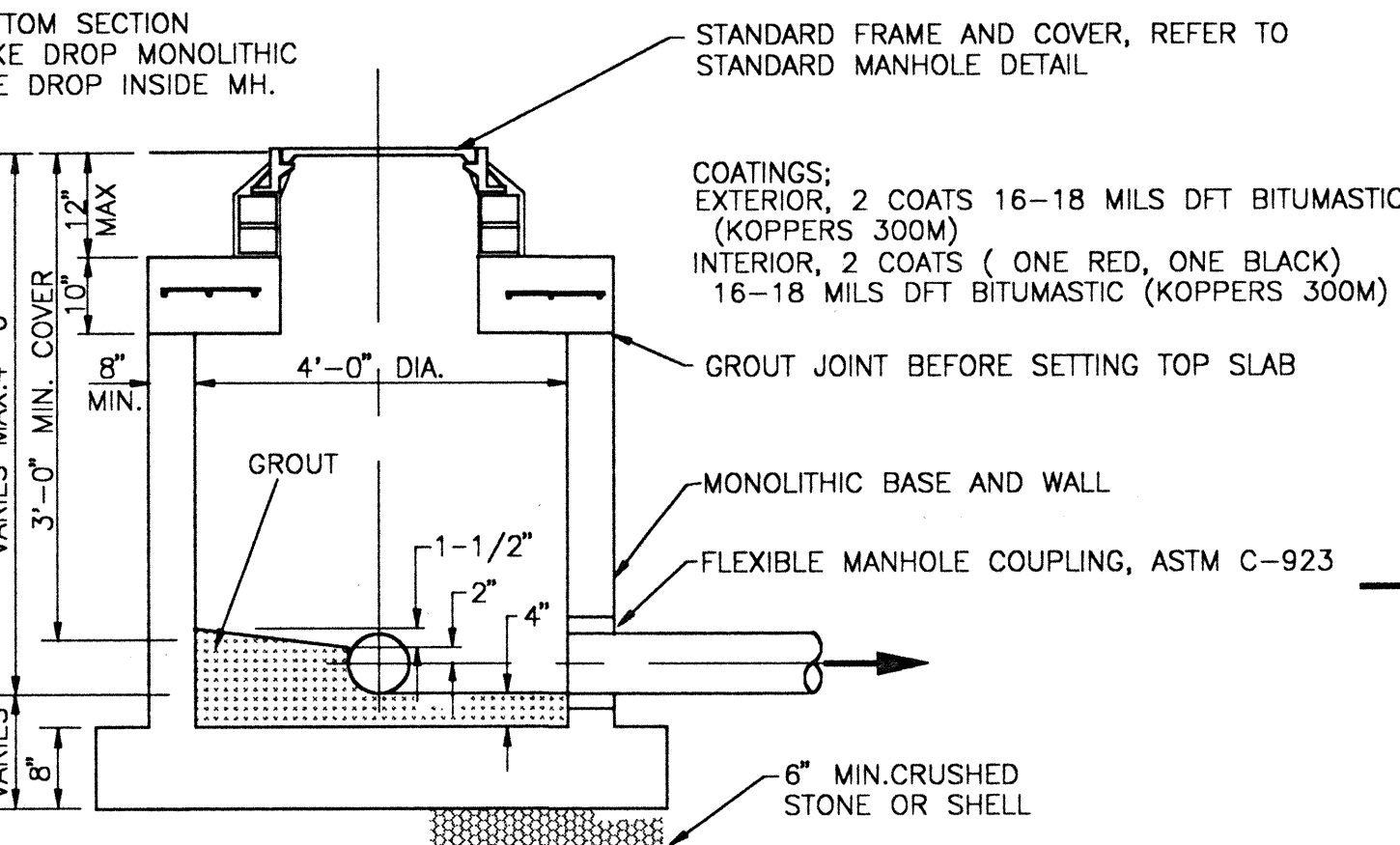

SHALLOW MANHOLE DETAIL

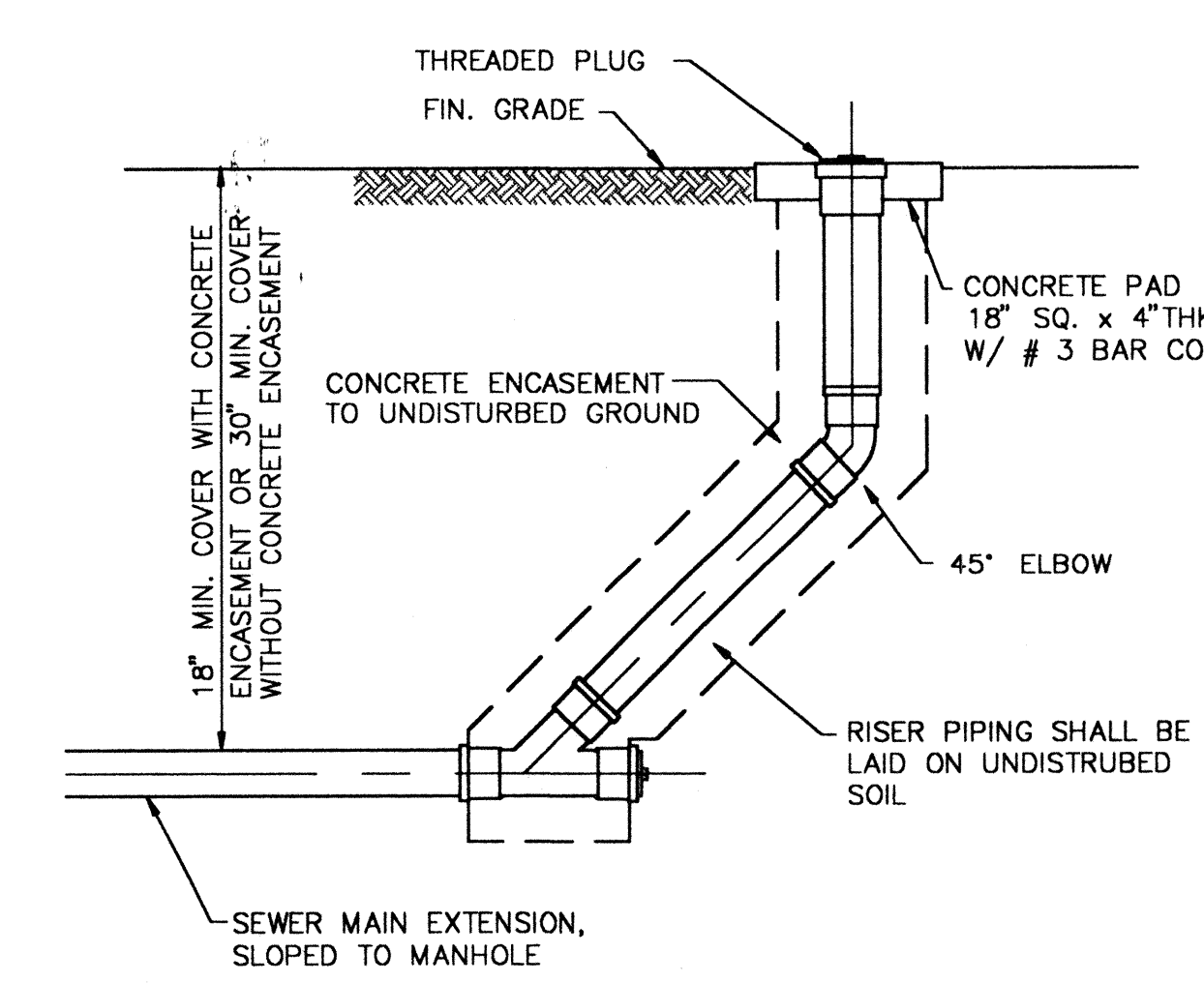

CLEAN OUT DETAIL

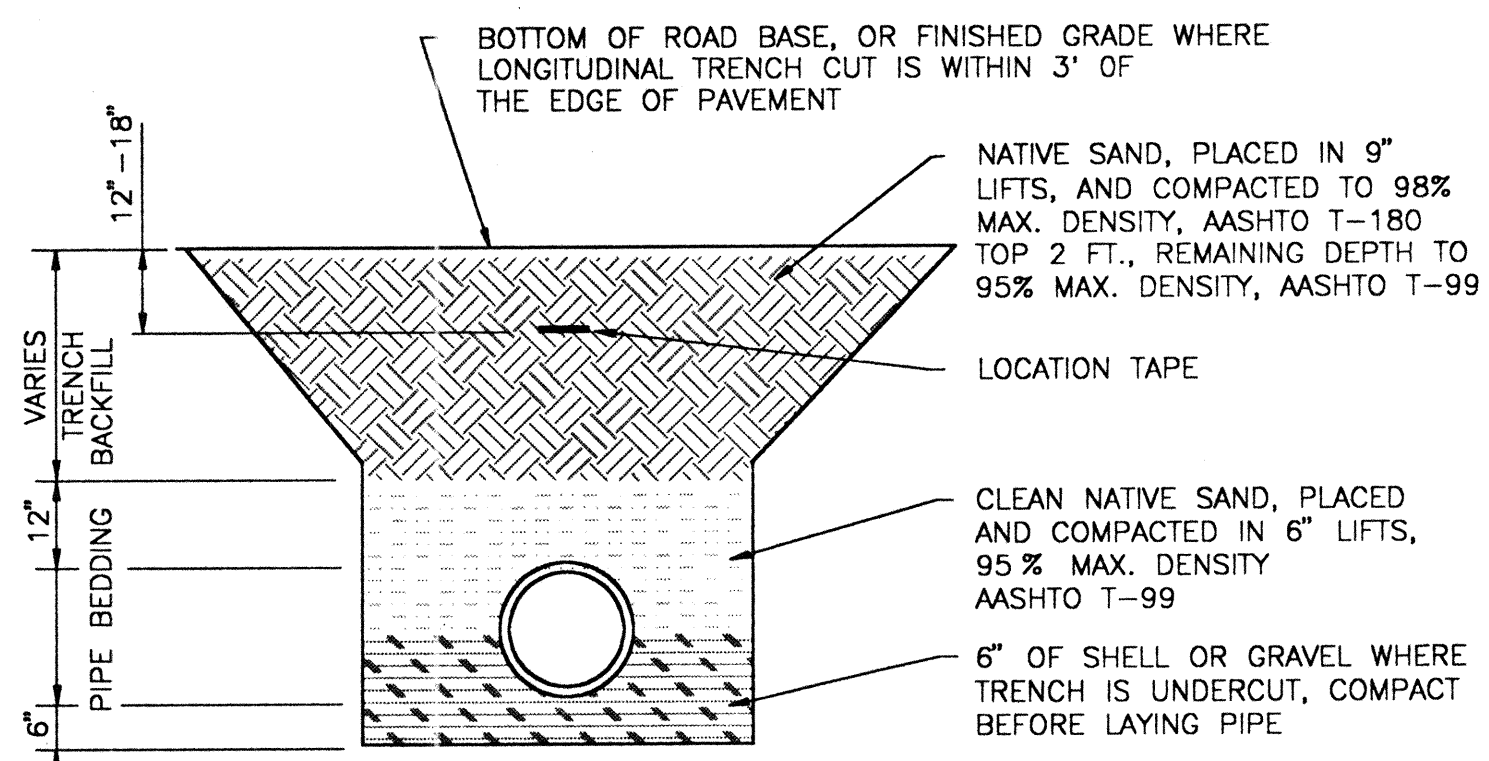

TRENCH "A" DETAIL

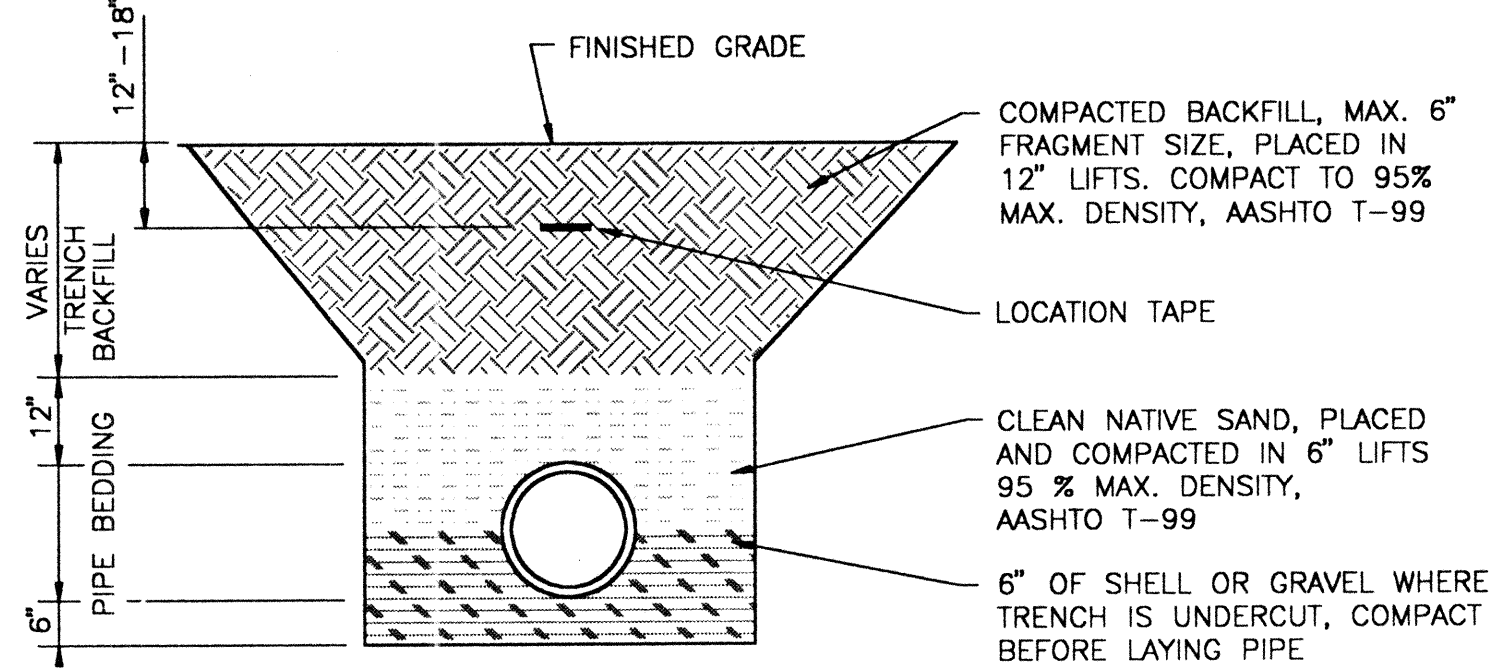

TRENCH "B" DETAIL

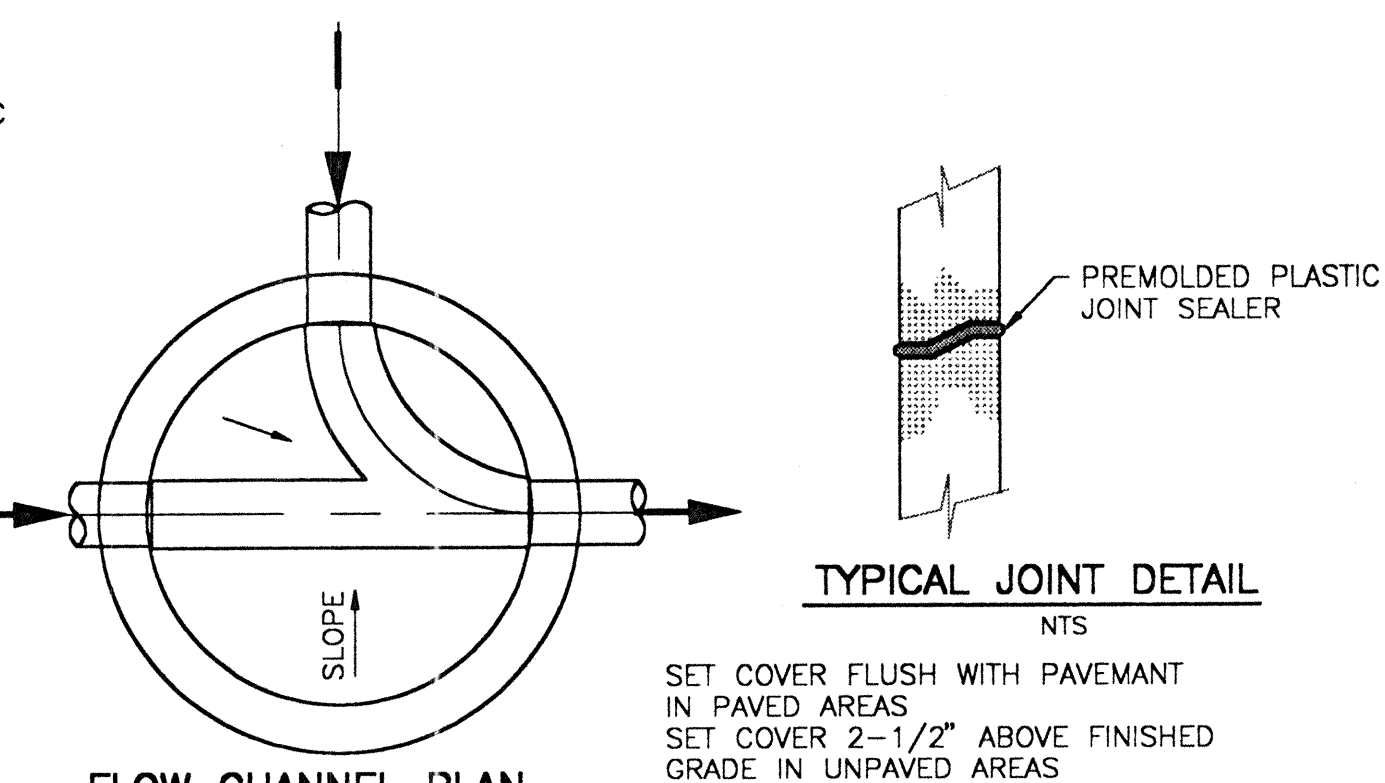

FLOW CHANNEL PLAN

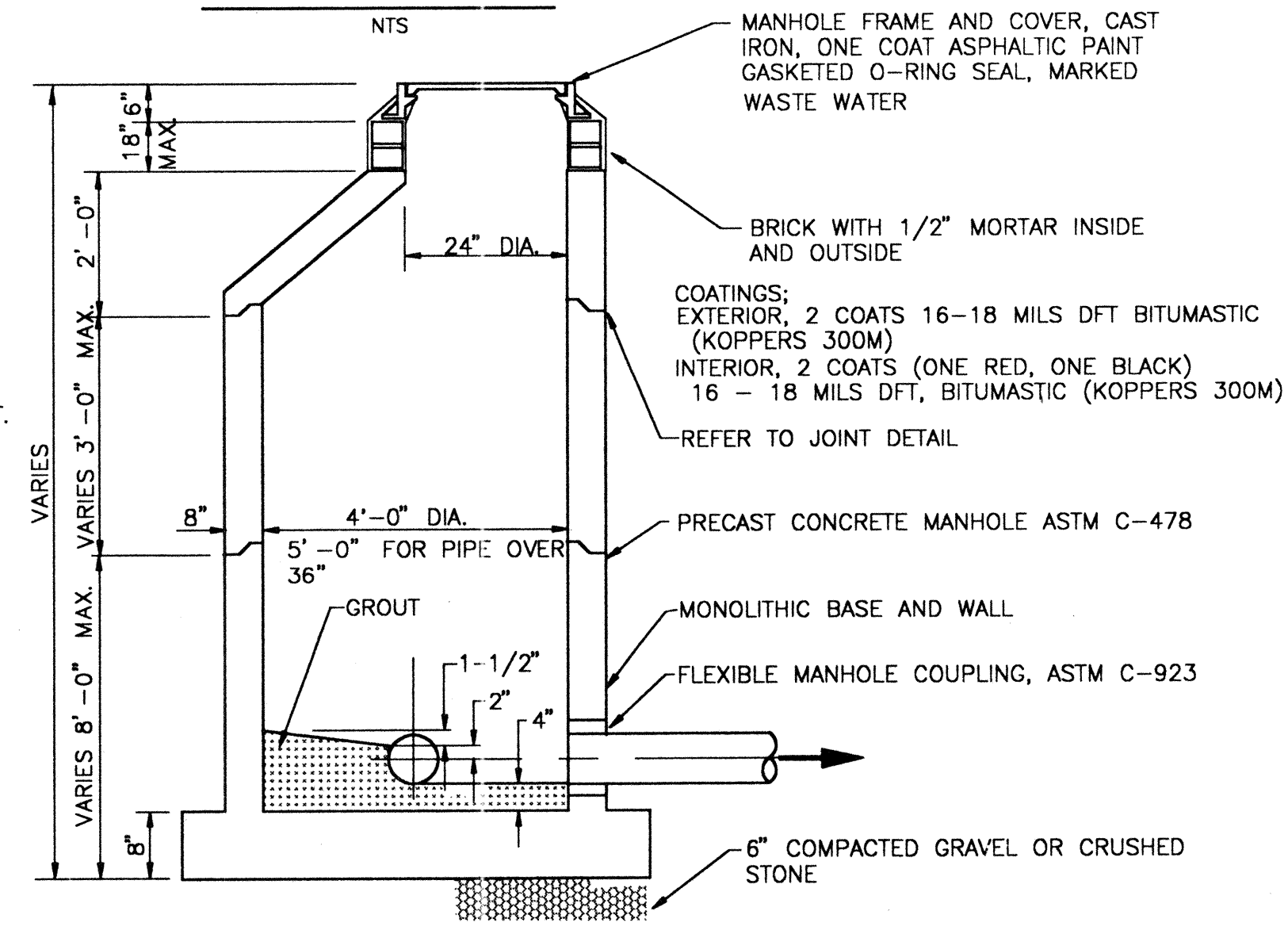

STANDARD MANHOLE

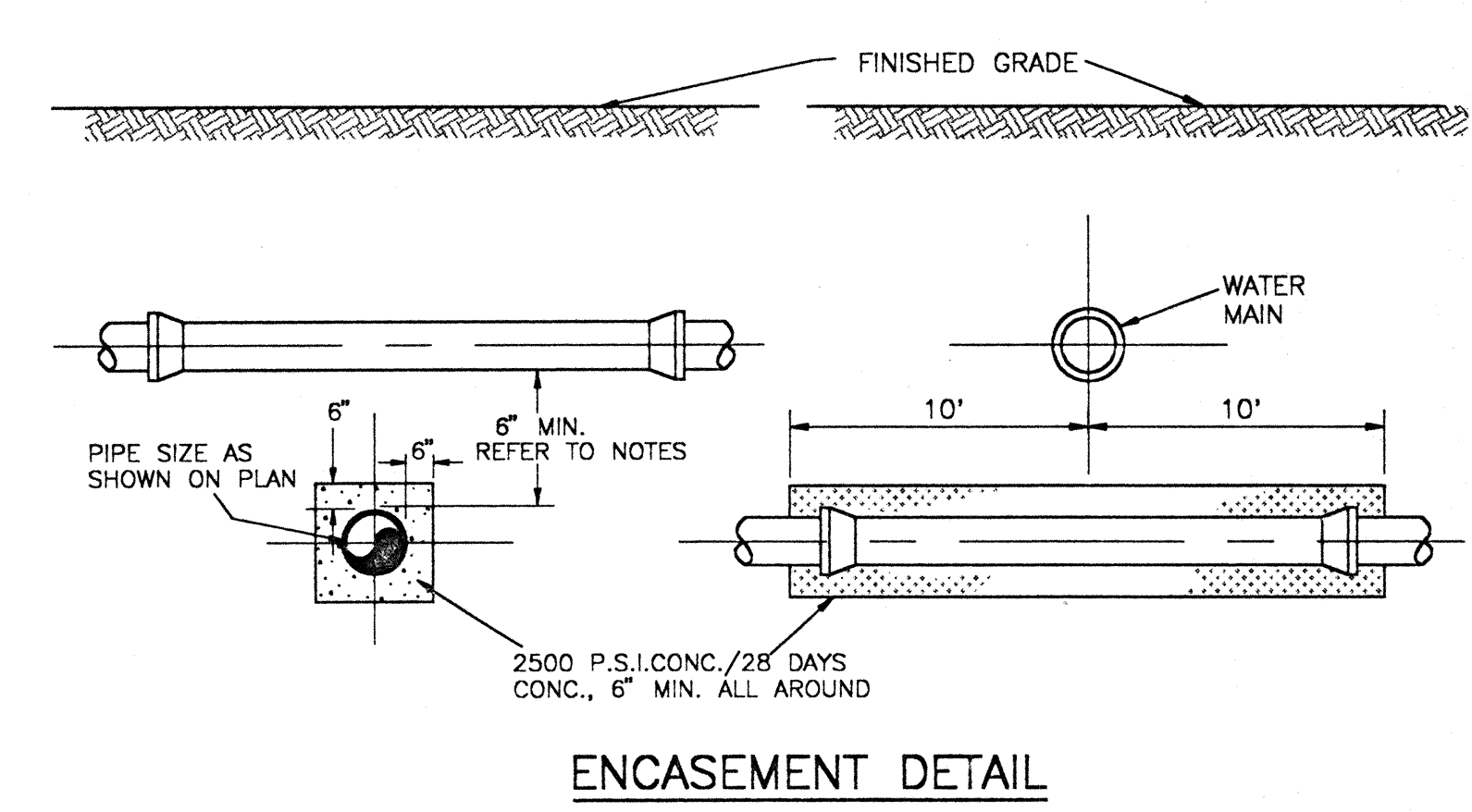

ENCASEMENT DETAIL

NOTES: (PROTECTION OF WATER SYSTEMS)

1. THE HORIZONTAL SEPARATION BETWEEN SANITARY SEWERS AND EXISTING OR PROPOSED WATER MAINS SHALL NOT BE LESS THAN 10 FEET. HOWEVER, SHOULD THE STIPULATED HORIZONTAL SEPARATION NOT BE POSSIBLE, THE SEWER PIPE SHALL BE COMPLETELY ENCASED (6 INCH MINIMUM) IN CONCRETE, CONSTRUCTED OF DUCTILE IRON PIPE WITH PRESSURE TIGHT JOINTS OR PROTECTED BY OTHER METHODS AS APPROVED BY THE ENGINEER.
2. UNLESS SEWER PIPES CROSS BELOW WATER MAINS WITH A VERTICAL SEPARATION OF 18 INCHES BETWEEN THE BOTTOM OF THE WATER MAIN AND TOP OF THE SEWER MAIN, SPECIAL PROTECTION SHALL BE PROVIDED. SAID PROTECTION SHALL CONSIST OF COMPLETELY ENCASED (6 INCH MINIMUM) THE WATER MAIN IN CONCRETE FOR A MINIMUM DISTANCE OF 10 FEET EACH SIDE OF THE WATER MAIN OR INSTALLATION OF DUCTILE IRON PIPE WITH PRESSURE TIGHT JOINTS FOR THE SAME DIMENSION.
3. IF A CROSSING WHERE THE SEWER MAIN IS LAID OVER THE WATER MAIN IS UNAVOIDABLE THEN THE ABOVE MENTIONED PRECAUTIONS SHALL BE OBSERVED REGARDLESS OF THE DISTANCE OF VERTICAL SEPARATION BETWEEN WATER MAINS AND SEWER MAINS.
4. USE OF D.I.P. IS THE PREFERRED METHOD AND SHALL BE USED WHERE SHOWN ON THE PLANS.

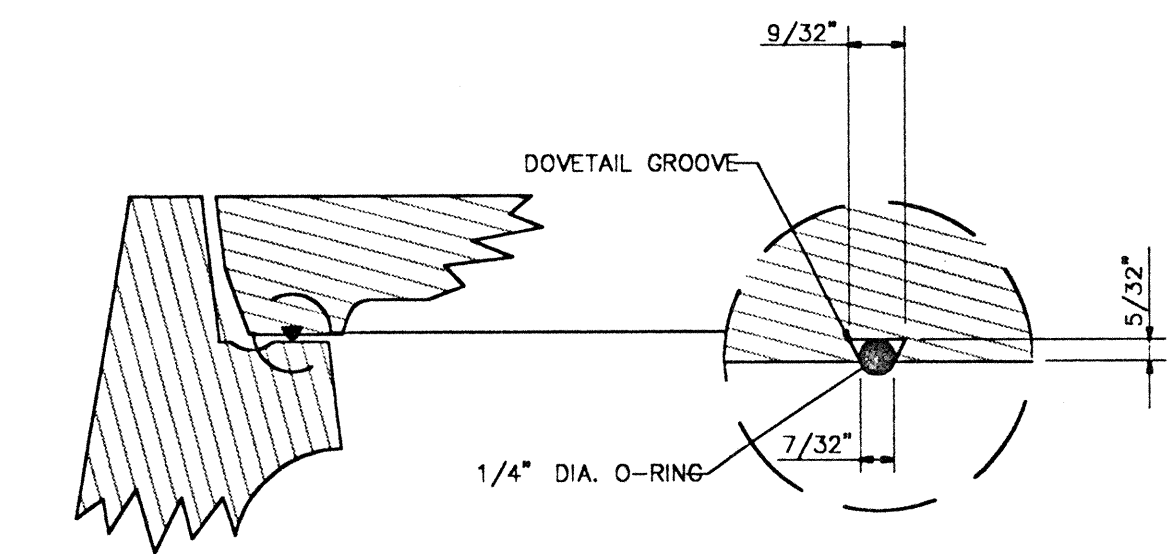

TYPICAL MANHOLE RING & COVER SECTION

DOVETAIL GROOVE DETAIL

(U.S. FOUNDARY & MFG. CORP.)
 N.T.S.

GENERAL NOTES:

1. WHERE WATER & WASTEWATER MAINS CROSS WITH LESS THAN 18" VERTICAL CLEARANCE, THE WASTEWATER PIPE SHALL BE OF EITHER DUCTILE IRON OR CONCRETE ENCASED PVC, (20' MIN.) CENTERED ON THE POINT OF CROSSING.
2. PARALLEL WATER & WASTEWATER MAINS SHALL MAINTAIN A HORIZONTAL SEPARATION OF AT LEAST 10'.
3. WHERE STORMWATER SEWERS CROSS OVER WASTEWATER SEWERS WITH LESS THAN 12" VERTICAL CLEARANCE, THE WASTEWATER PIPE SHALL BE EITHER DUCTILE IRON OR CONCRETE ENCASED PVC, 10' MIN. EITHER SIDE OF CROSSING.

MANHOLE SPECIFICATIONS:

1. MANHOLES SHALL COMPLY WITH A.S.T.M. SPECS. C-478, LATEST REVISION, "PRECAST REINFORCED CONCRETE MANHOLE SECTIONS".
2. CONCRETE SHALL BE 4,000 P.S.I./28 DAY MINIMUM STRENGTH, WITH TYPE II CEMENT.
3. HEAVY DUTY MANHOLE RING (6" HIGH) AND COVER SHALL BE TYPE B (DWG. NO. 240; OLD NO. 24) WITH FRAME AND DOVETAIL GROOVED COVER (325 LB) TO ACCOMMODATE 1/4" DIA., O-RING AS MANUFACTURED BY U.S. FOUNDARY CORP., MIAMI, FLORIDA, OR APPROVED EQUAL, WITH THE WORDS "WASTE WATER" CAST INTO COVER.
4. REINFORCING PER A.S.T.M. SPEC. C-478, LATEST REVISION
5. LEVELING BRICKS TO BE CLAY; MORTAR TO BE TWO PARTS CLEAN SAND AND ONE PART CEMENT WITH NO MORE THAN 1/4 PART HYDRATED LIME, WITH JOINTS FULL AND STRUCK FLUSH.
6. NO STEPS SHALL BE USED.
7. COMPLETELY FILL SPACE BETWEEN PIPES AND MANHOLE WALL WITH CEMENT MORTAR AFTER PIPE IS SET WITH 15 LB. EMBCO PER 100 LB. CEMENT.

| | |
|-----------|----------|
| DATE: | 5/4/93 |
| SCALE: | AS NOTED |
| DESIGN: | STAFF |
| DRAWN: | RMC |
| CHECKED: | CA |
| DATE: | 03/13/93 |
| APPROVED: | |

| | |
|--------------|------|
| APPROVED: | |
| PROJECT NO.: | 2200 |
| SHEET NO.: | 10 |