

DETAIL 1

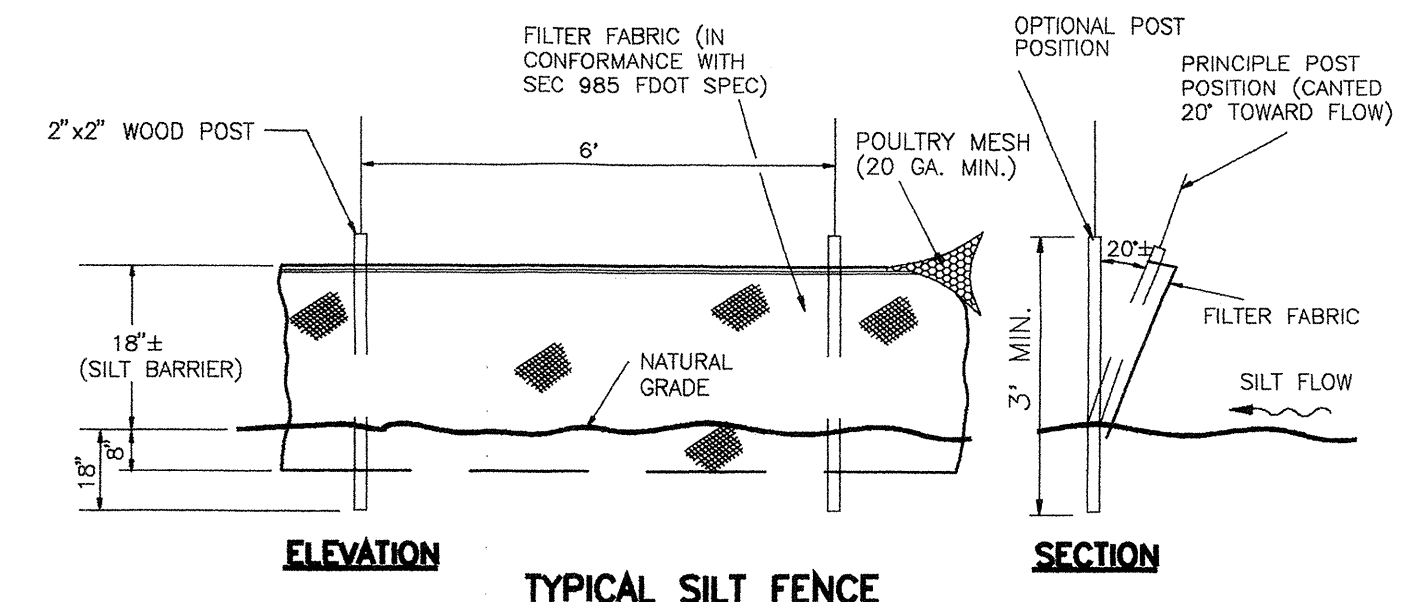

DETAIL 2

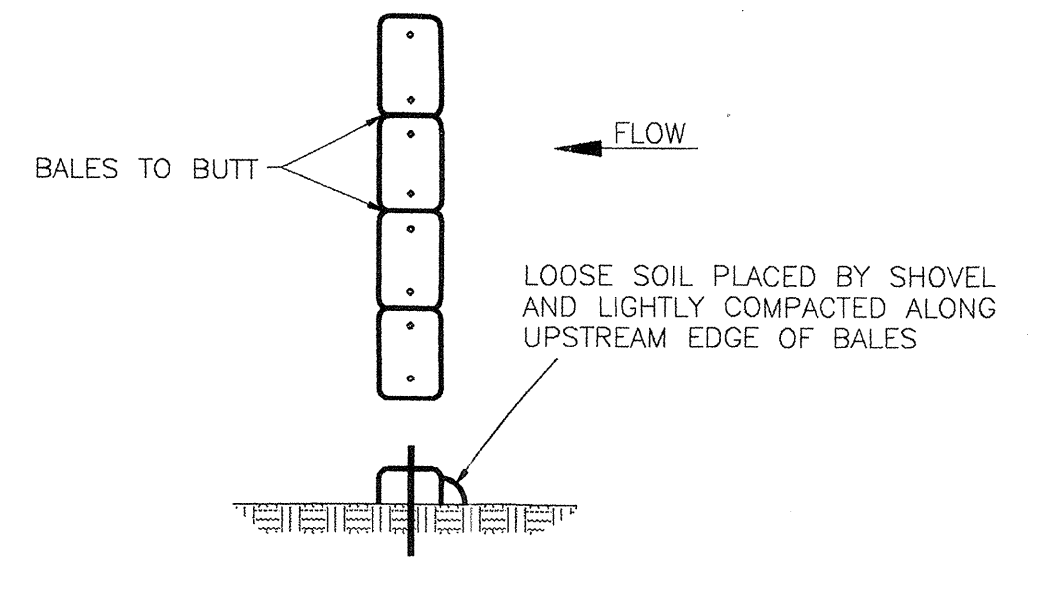

DETAIL 3

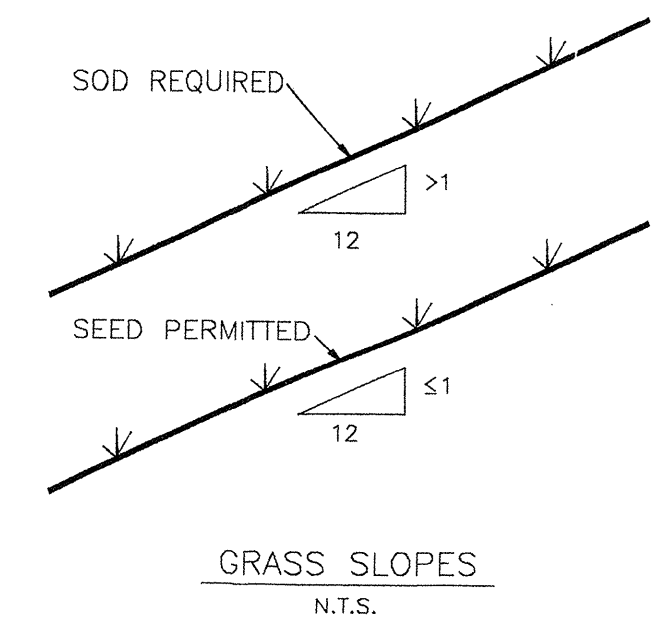

DETAIL 4

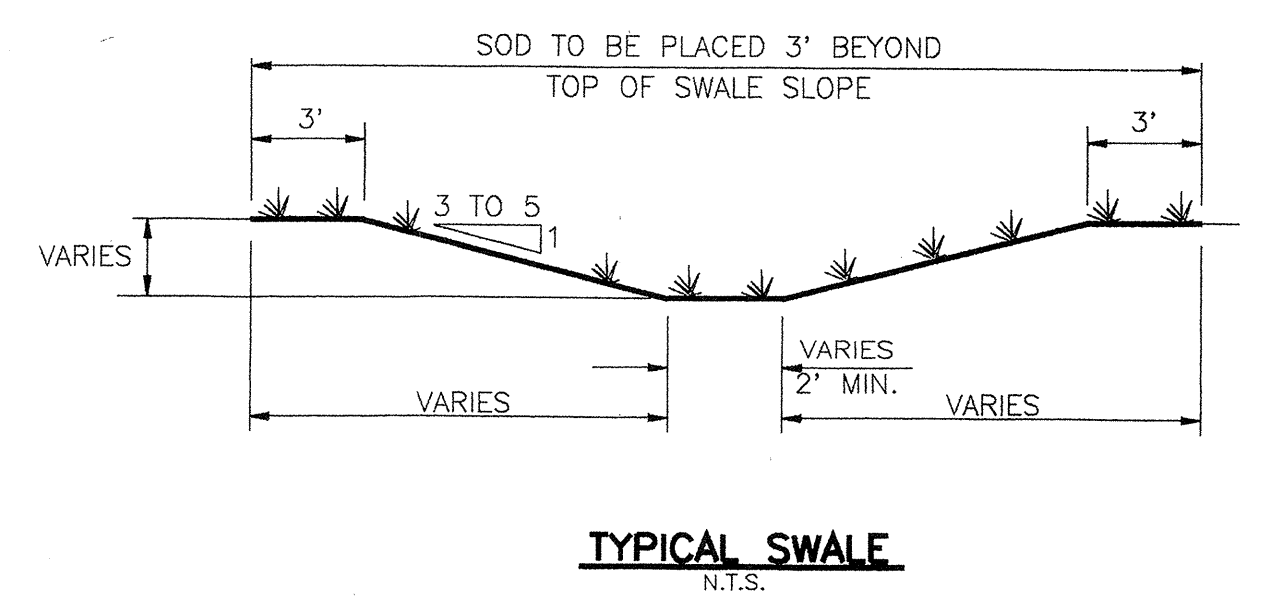

DETAIL 5

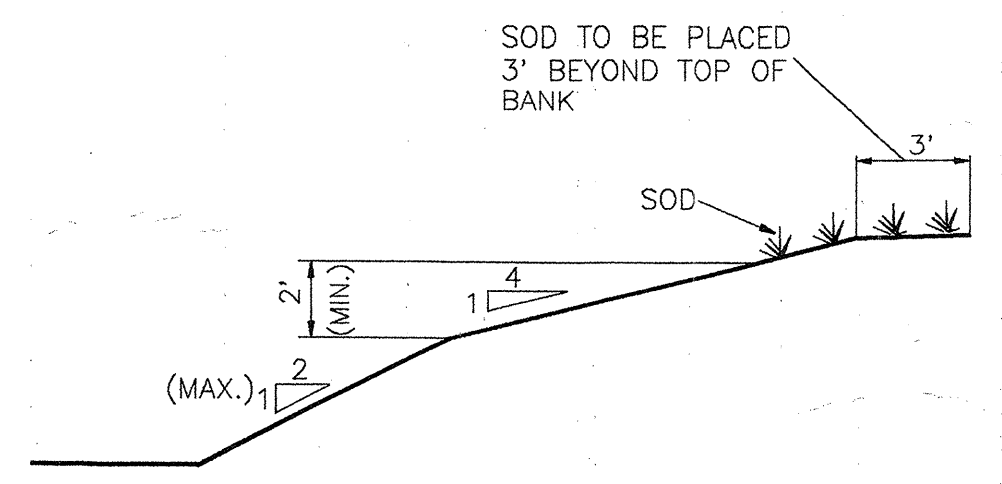

TYPICAL RETENTION/DETENTION POND SECTION

DETAIL 6

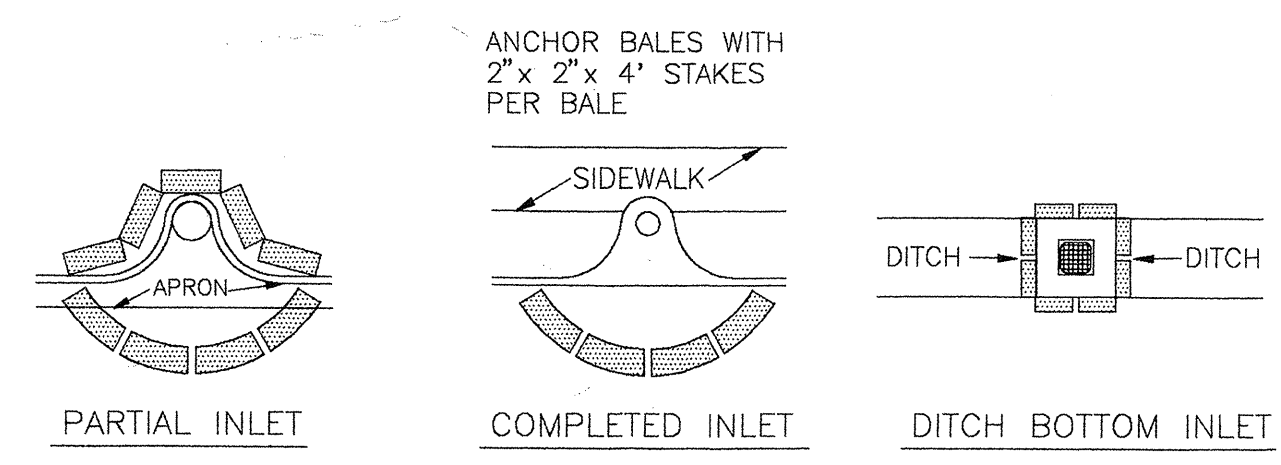

PROTECTION AROUND INLETS

DETAIL 7

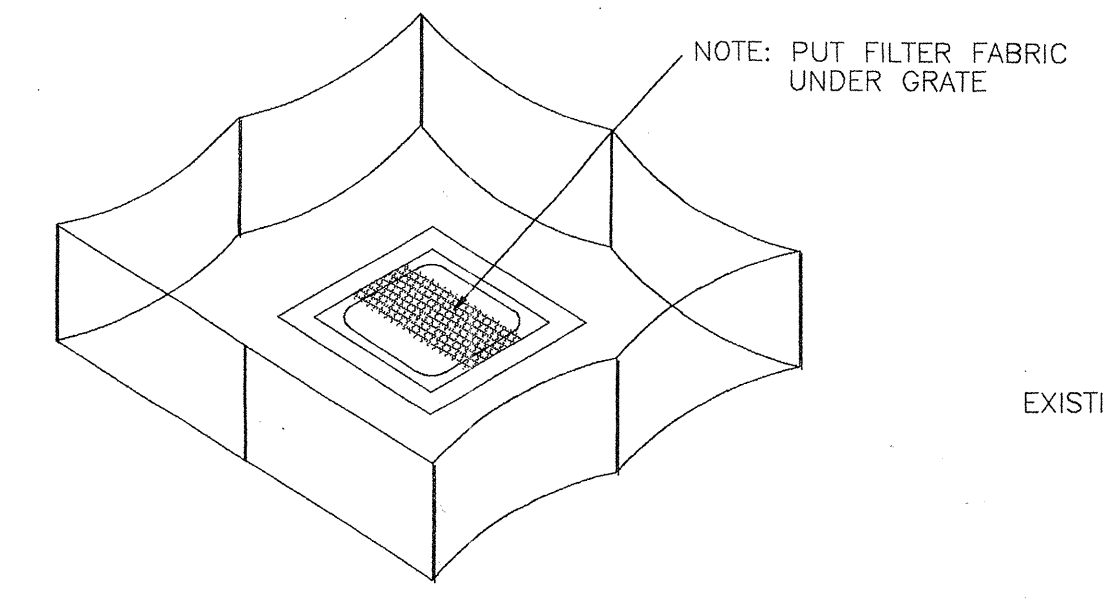

STAKED SILT BARRIER OR SILT FENCE PROTECTION AROUND DITCH BOTTOM INLETS

DETAIL 8

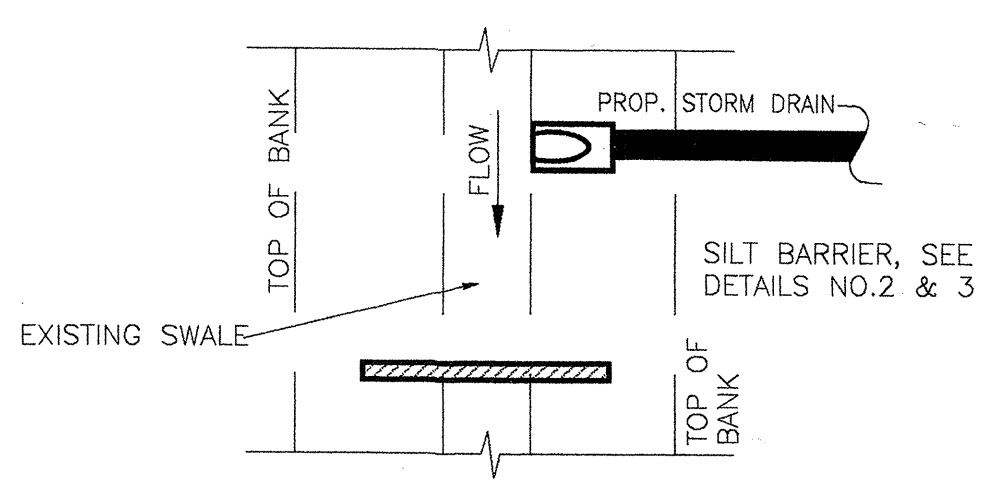

SILT BARRIER AT CONNECTION OF STORM PIPE TO EXISTING SWALE

DETAIL 9

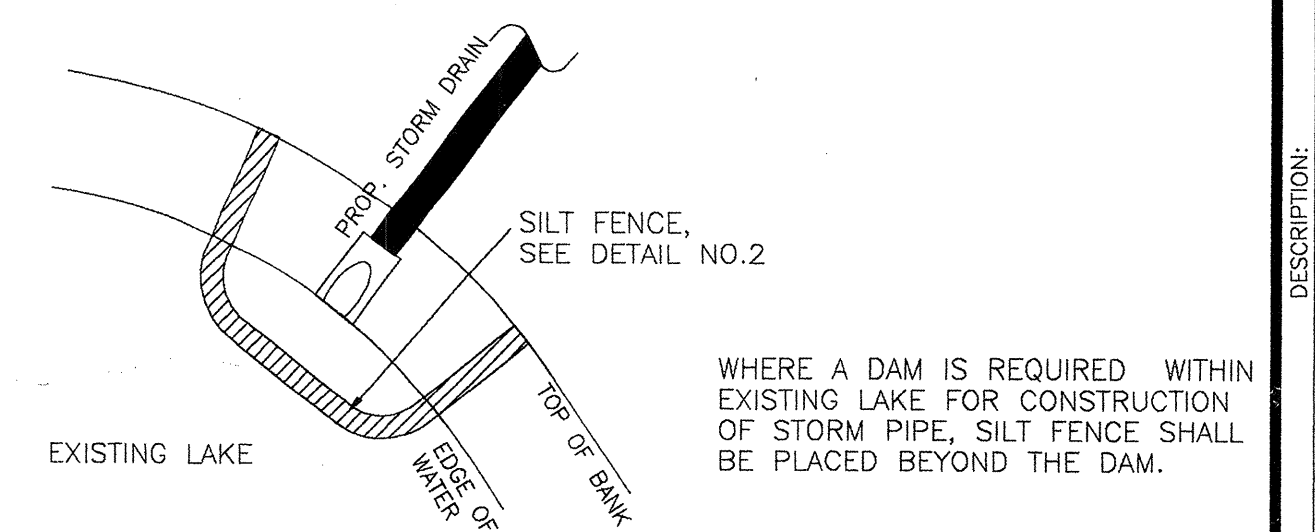

SILT BARRIER AT CONNECTION OF STORM PIPE TO EXISTING LAKE

DETAIL 10

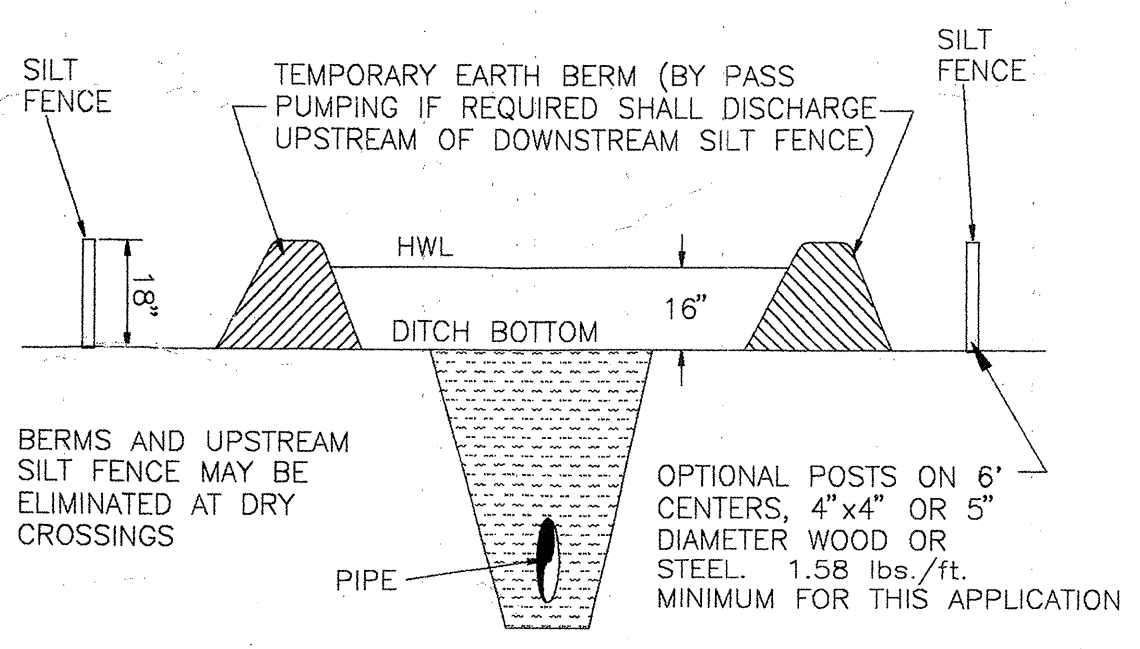

UNDERGROUND PIPE CROSSINGS

DETAIL 11

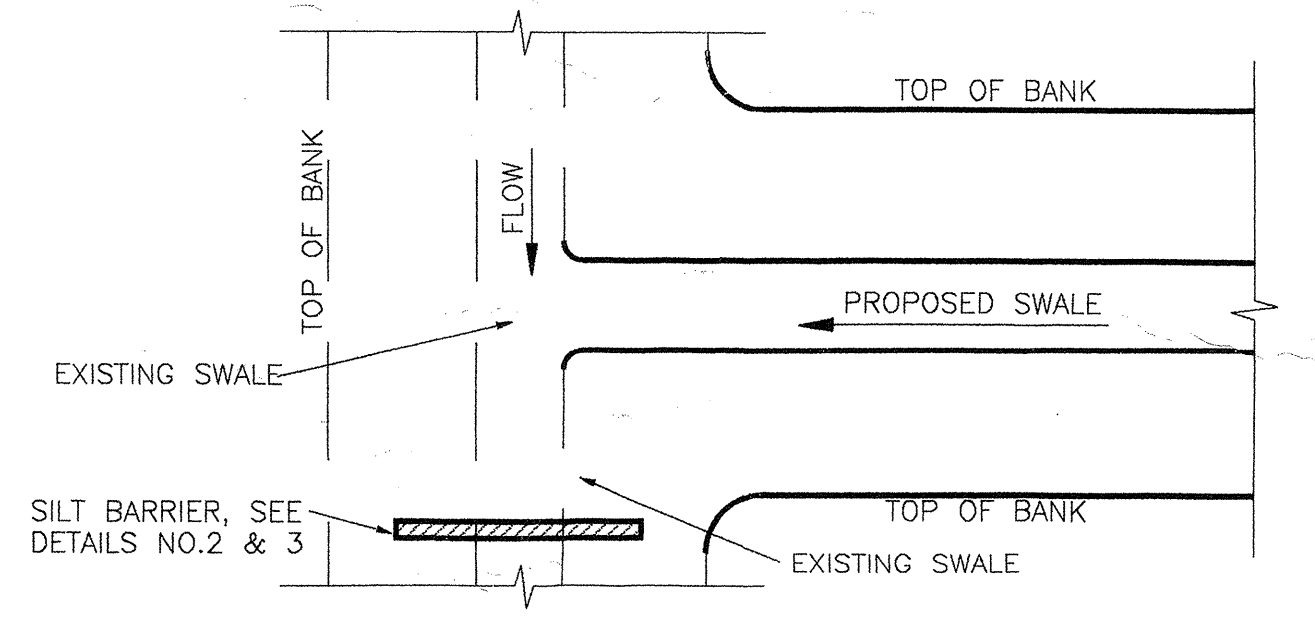

SILT BARRIER AT CONNECTION OF SWALE TO EXISTING SWALE

DETAIL 12

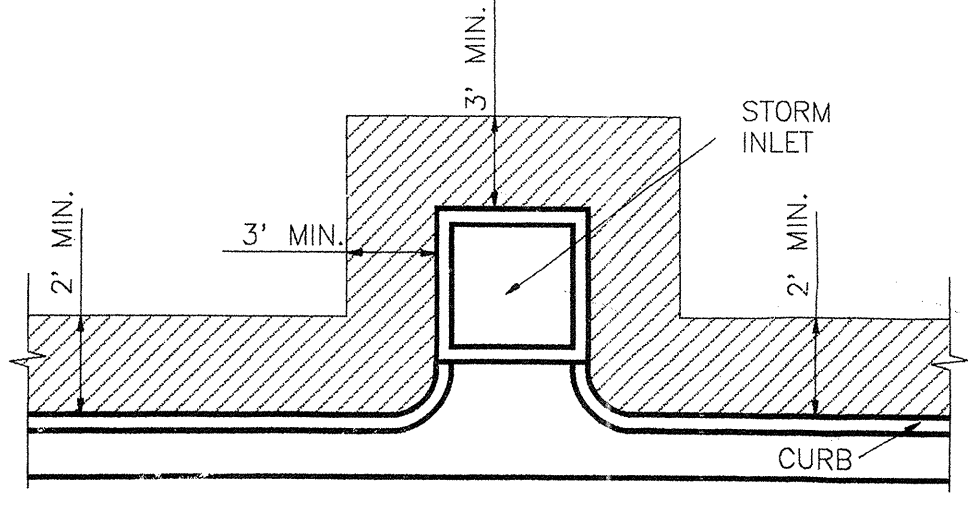

SOD ALONG CURB AND AROUND INLET

DETAIL 13

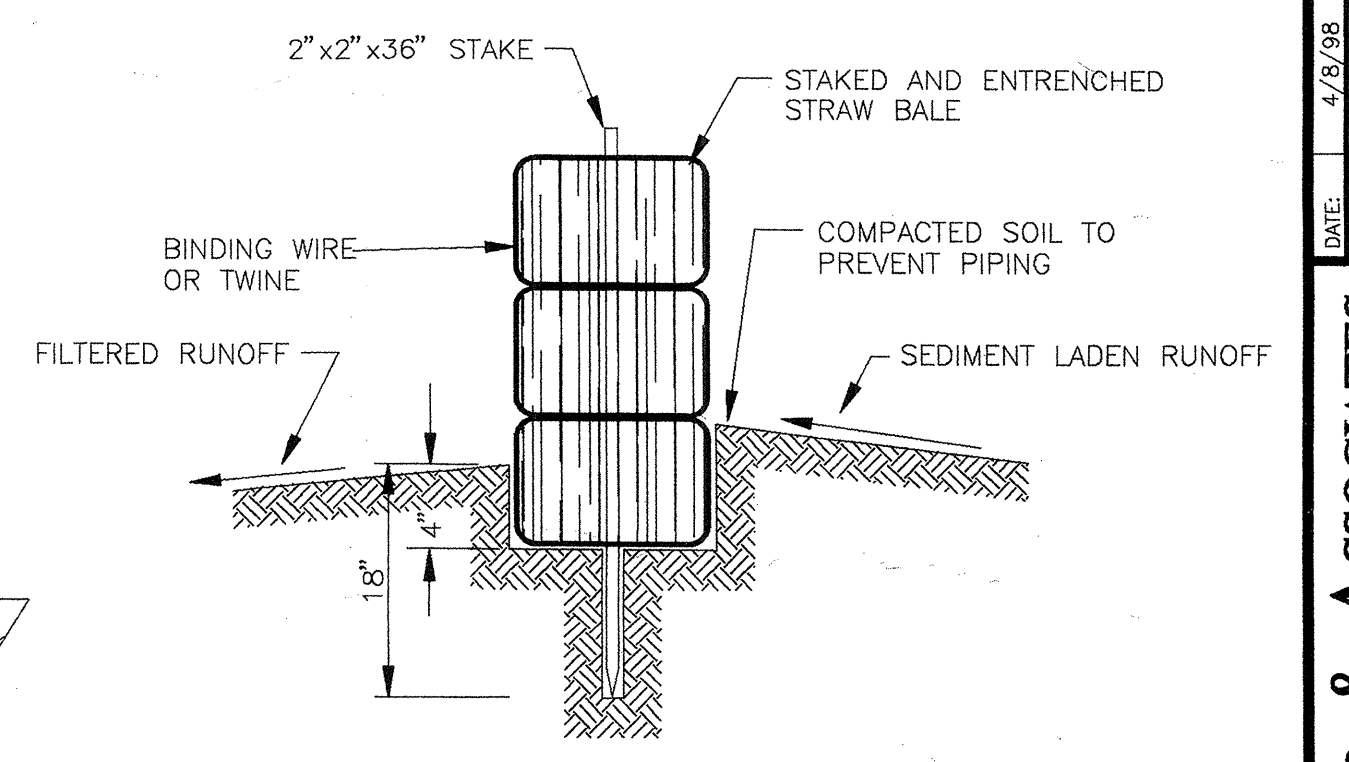

SECTION A-A

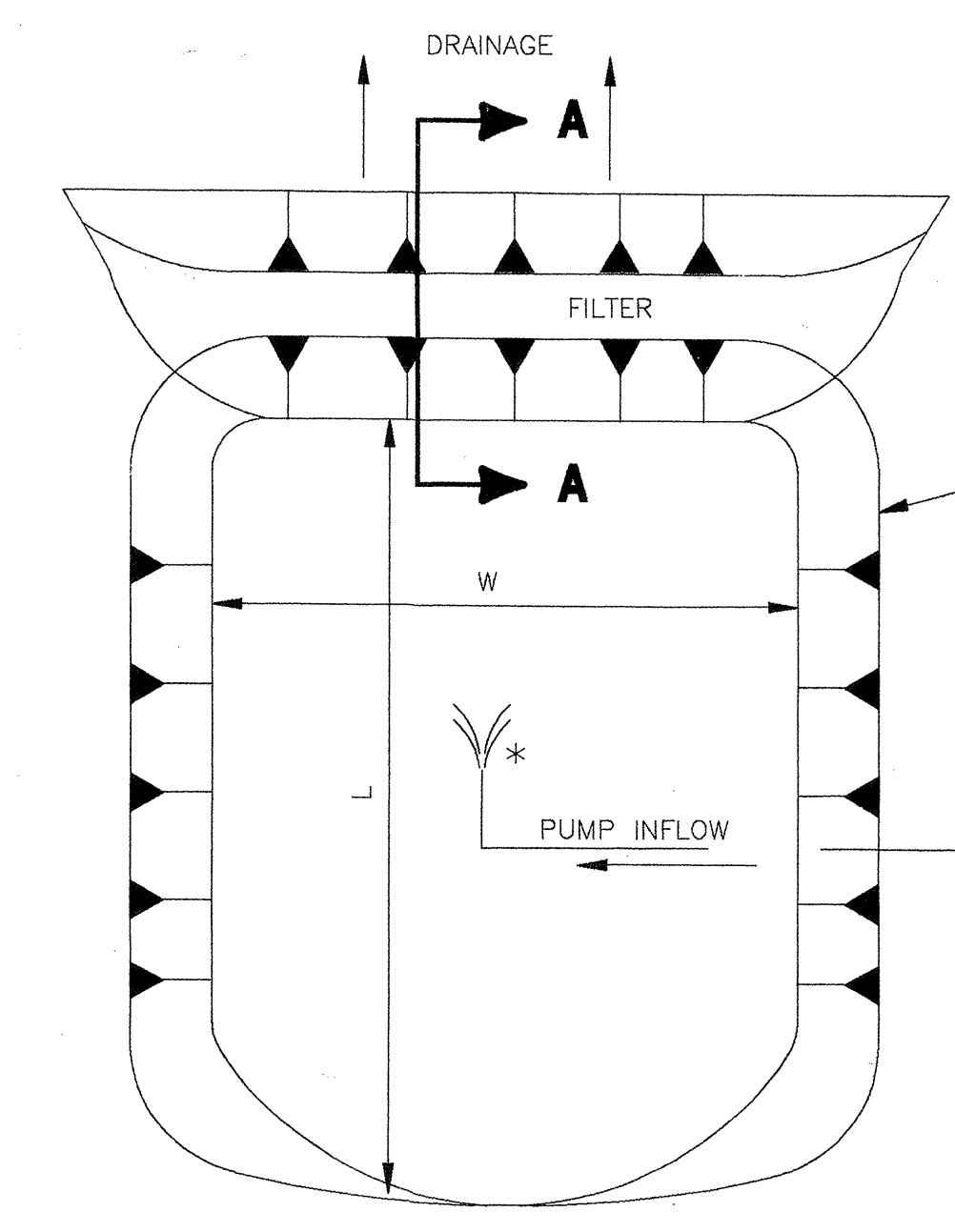

DEWATERING SEDIMENT AND EROSION CONTROL SUMP

DETAIL 15

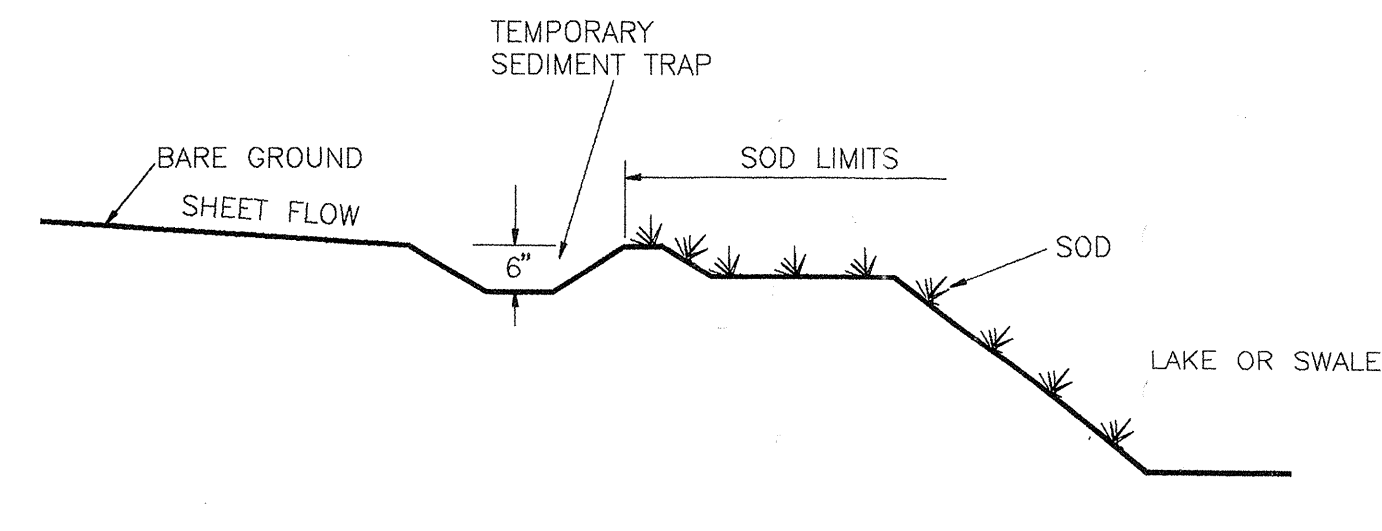

SILT BARRIER AT CONNECTION OF SWALE TO EXISTING SWALE

DETAIL 14

- NOTES:**
1. EROSION AND SEDIMENT CONTROL APPLICATIONS MUST BE MAINTAINED FOR ENTIRE DURATION OF PROJECT OR UNTIL SODDING AND/OR GRASS IS ESTABLISHED AS DIRECTED BY ENGINEER.
 2. DURING CONSTRUCTION ALL MEASURES FOR EROSION AND SEDIMENT CONTROL WILL BE TAKEN, INCLUDING BUT NOT LIMITED TO, USE OF TURBIDITY SCREENS, MULCHING, HAY BALES, AND SOD PLACEMENT AT THE EARLIEST POSSIBLE TIME AFTER EXCAVATION/GRADING. ALL SILTATION/EROSION CONTROL MEASURES WILL BE TAKEN WHICH MEET THE STATE OF FLORIDA D.O.T. INDEX NO. 102 & 103.
 3. EROSION AND SEDIMENT CONTROL MEASURES FOR FLOWING STREAMS AND TIDAL CREEKS MAY BE EITHER FLOATING (NOT SHOWN), FENCE OR STAKED TYPES OR ANY COMBINATIONS OF TYPES THAT WILL SUIT SITE CONDITIONS AND MEET EROSION & SEDIMENT CONTROL AND WATER QUALITY REQUIREMENTS INCORPORATED IN VARIOUS ENVIRONMENTAL PERMITS FOR THIS JOB. THE CONTROL MEASURES WILL BE AT THE CONTRACTOR'S OPTION. MEASURES SHOWN ON THESE PLANS ARE FOR INFORMATION PURPOSES ONLY. COSTS OF EROSION CONTROL ITEMS TO BE INCLUDED IN CONTRACT PRICE OF INLETS, PIPING, STORMWATER MANAGEMENT SYSTEM.
 4. EROSION & SEDIMENT CONTROL MEASURES SHALL BE PLACED TO CONTAIN ALL POINTS OF DISCHARGE TO SURFACE WATERS INCLUDING CURB INLETS, DITCH BOTTOM INLETS, DITCHES, AND DOWNSTREAM PORTIONS OF STREAMS AND TIDAL WATERS ADJACENT TO CONSTRUCTION.
 5. PRESERVED AREAS SHALL BE PROTECTED PRIOR TO START OF ANY CLEARING OR SITEWORK CONSTRUCTION. PROTECTION SHALL CONSIST OF A SILT BARRIER ERECTED ALONG THE PERIMETER OF THE PRESERVED WETLAND AS SHOWN IN DETAIL NO.1. SILT BARRIERS USED FOR WETLAND PROTECTION SHALL REMAIN IN PLACE UNTIL ALL CONSTRUCTION IS COMPLETE.
 6. SILT BARRIERS ERECTED DURING CONSTRUCTION SHALL BE MAINTAINED SUCH THAT CASUAL WATER WILL DRAWDOWN WITHIN 72 HOURS. AT THE END OF EACH DAY ANY SILT WHICH HAS ACCUMULATED BEHIND THE BARRIERS SHALL BE REMOVED PROMPTLY.
 7. CLEARED SITE DEVELOPMENT AREAS NOT CONTINUALLY SCHEDULED FOR CONSTRUCTION ACTIVITIES SHALL BE COVERED WITH HAY OR OVERSEEDED AND PERIODICALLY WATERED SUFFICIENT TO STABILIZE THE TEMPORARY GROUND COVER.
 8. ALL SPOIL MATERIALS AND REFUSE RESULTING FROM THE CLEARING AND GRUBBING OPERATION SHALL BE TRANSPORTED AND DISPOSED BY THE CONTRACTOR AT AN APPROVED OFF-SITE LOCATION.
 9. THE CONTRACTOR SHALL NOT CLEAR OR GRUB ANY AREA BEYOND THE LIMITS OF CONSTRUCTION AS LAID OUT BY THE ENGINEER.
 10. WIND EROSION SHALL BE CONTROLLED BY UTILIZING WATER TRUCKS AND ANTI-DRAFT FENCING IF REQUIRED. ANTI-DRAFT FENCING SHALL BE ERECTED AS SHOWN IN DETAIL NO.2 EXCEPT THE MINIMUM HEIGHT WILL BE 4 FEET.
 11. WHERE REQUIRED TO PREVENT EROSION FROM SHEET FLOW ACROSS BARE GROUND FROM A SWALE, A TEMPORARY SEDIMENT SUMP SHALL BE CONSTRUCTED.
 12. THE CONTRACTOR SHALL PLACE SOD AROUND ALL STORM INLETS AS SHOWN AND A 2 FOOT WIDE STRIP BEHIND ALL EDGE OF PAYMENT AS SHOWN IN DETAIL NO.13. SOD SHALL BE PLACED PRIOR TO REMOVAL OF THE SILT BARRIERS.
 13. HEAVY CONSTRUCTION EQUIPMENT PARKING AND MAINTENANCE AREAS SHALL BE DESIGNED TO PREVENT OIL, GREASE, AND LUBRICANTS FROM MIGRATING OUT OF THE DESIGNATED PARKING AREA. IF ANY SPILLS OCCUR, THE CONTRACTOR SHALL USE ABSORBENT FILTER PADS TO CLEAN UP THE SPILL AS SOON AS POSSIBLE.
 14. HEAVY CONSTRUCTION EQUIPMENT WILL NOT BE USED WITHIN THE PRESERVE AREAS. ONLY MANUAL LABOR WILL BE PERMITTED.
 15. THE CONTRACTOR WILL PERFORM DAILY INSPECTIONS TO ASSURE CONTINUED OPERATION OF TURBIDITY CONTROL MEASURES AND WILL PERFORM CORRECTIONS AS NEEDED.

DATE:	2/28/03
BY:	SN/SJK/32
DESCRIPTION:	
DATE:	2/28/03
DESIGNED BY:	AS/STED
CHECKED BY:	N/A
DATE:	
DESIGNED BY:	WBH
CHECKED BY:	DBH

ESBER & ASSOCIATES
Engineers • Surveyors
5914 Palmer Blvd. Sarasota, FL 34235
(941) 579-0861 • Fax (941) 579-0506

APPROVED: *[Signature]* DATE: *[Blank]*
ENGINEER OF RECORD
NOT ISSUED FOR CONSTRUCTION

[Handwritten Signature]
1/2/03