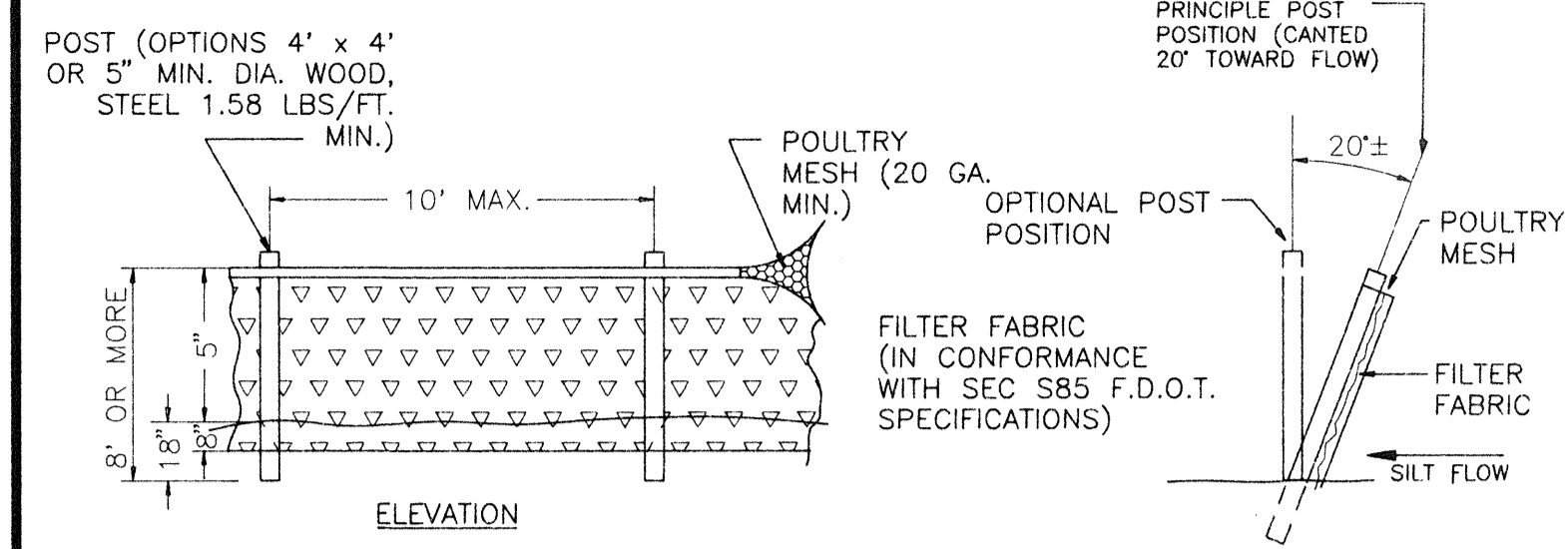

FIGURE 1



TYPICAL SILT FENCE
N.T.S.

FIGURE 2

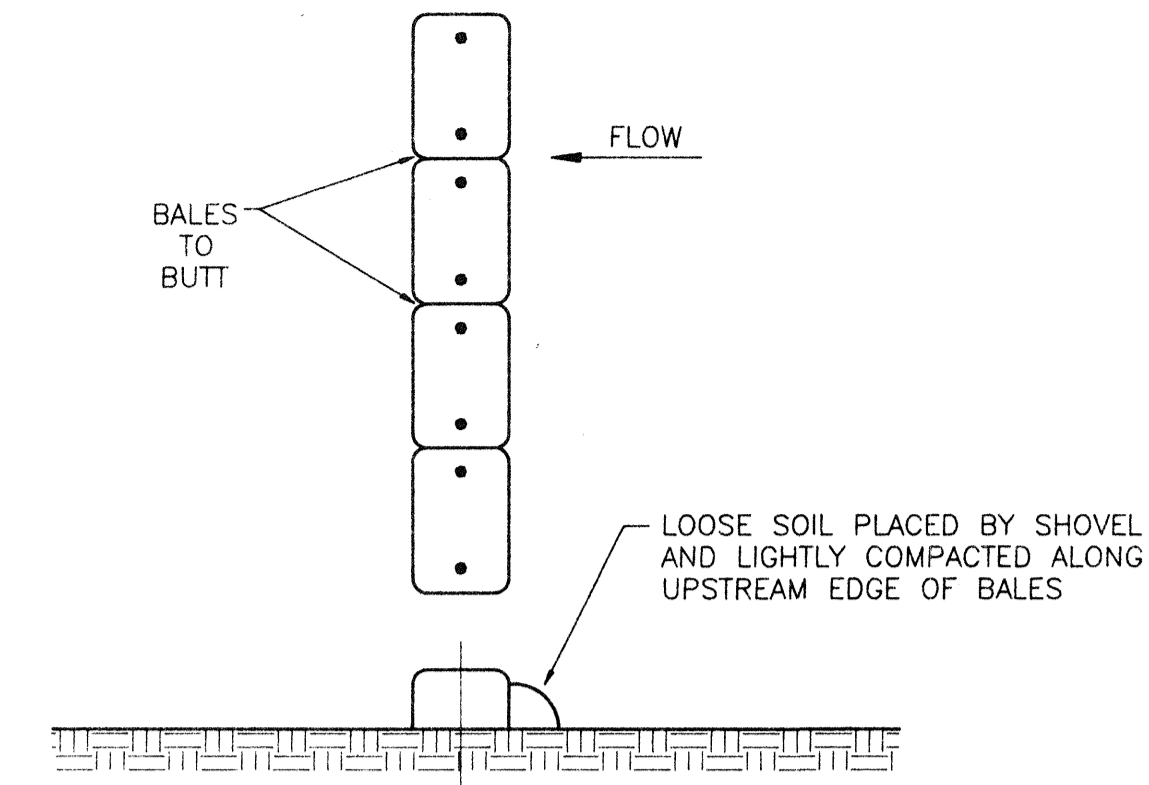
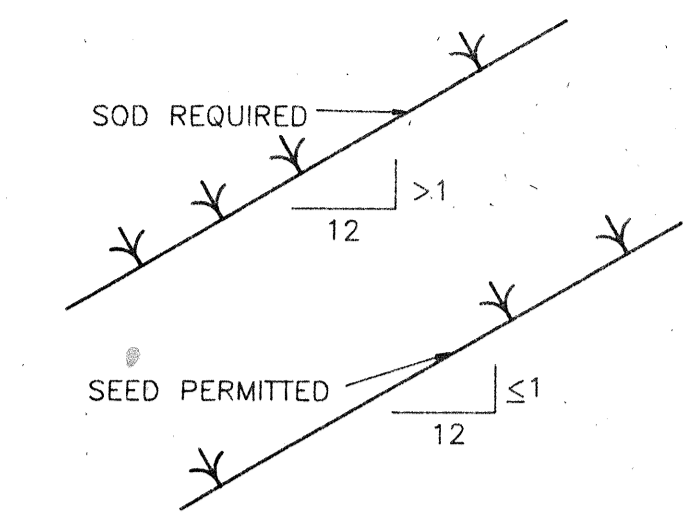
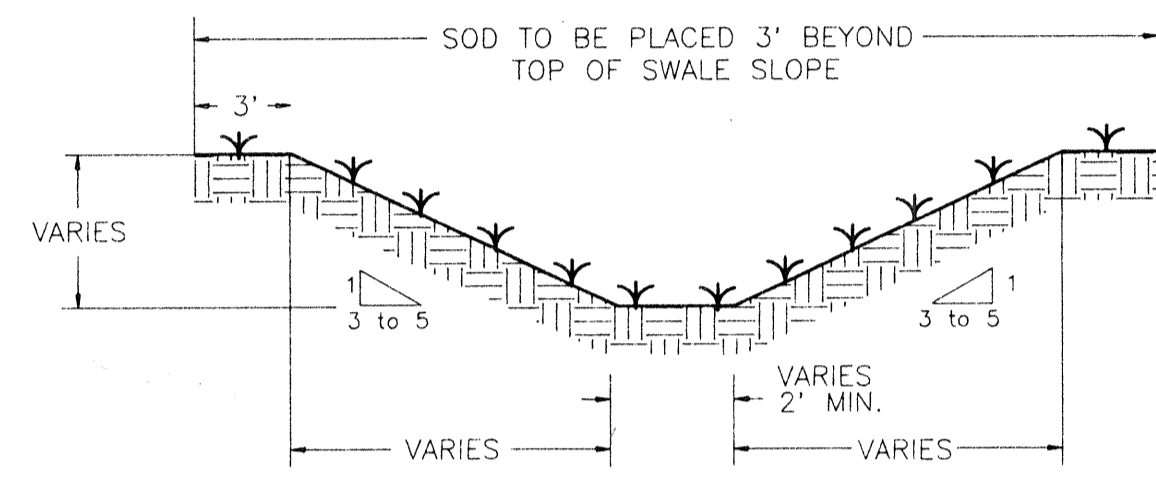

FIGURE 3



GRASS SLOPES
N.T.S.

FIGURE 4



TYPICAL SWALE SECTION
N.T.S.

FIGURE 5

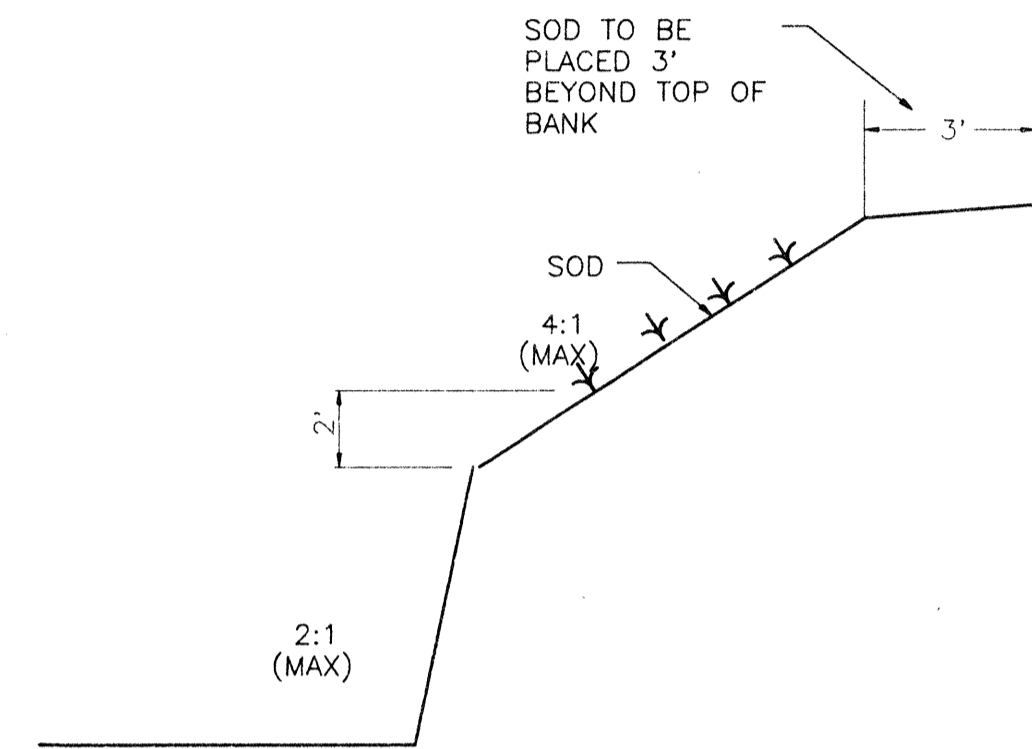

TYPICAL RETENTION/DETENTION
POND SECTION
N.T.S.

FIGURE 6

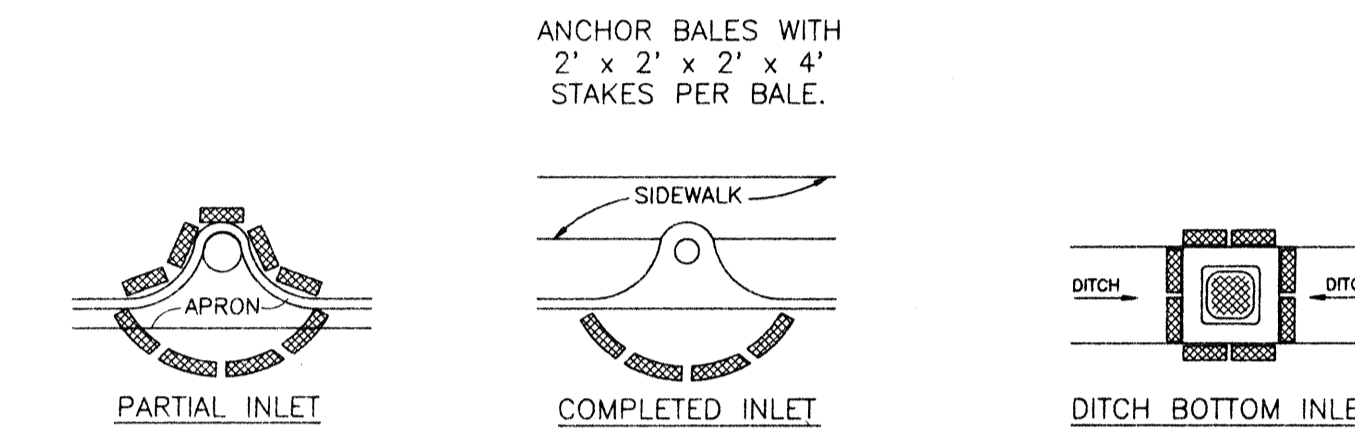

PROTECTION AROUND INLETS OR SIMILAR STRUCTURES
N.T.S.

FIGURE 7

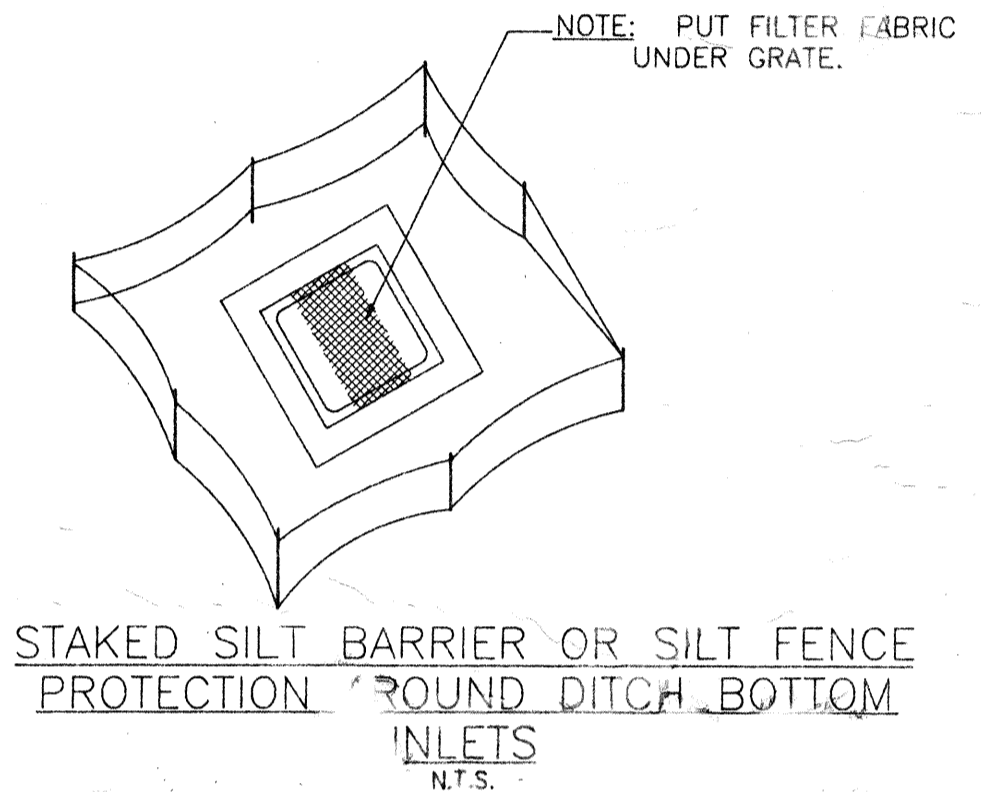

STAKED SILT BARRIER OR SILT FENCE
PROTECTION AROUND ROUND DITCH BOTTOM
INLETS
N.T.S.

FIGURE 8

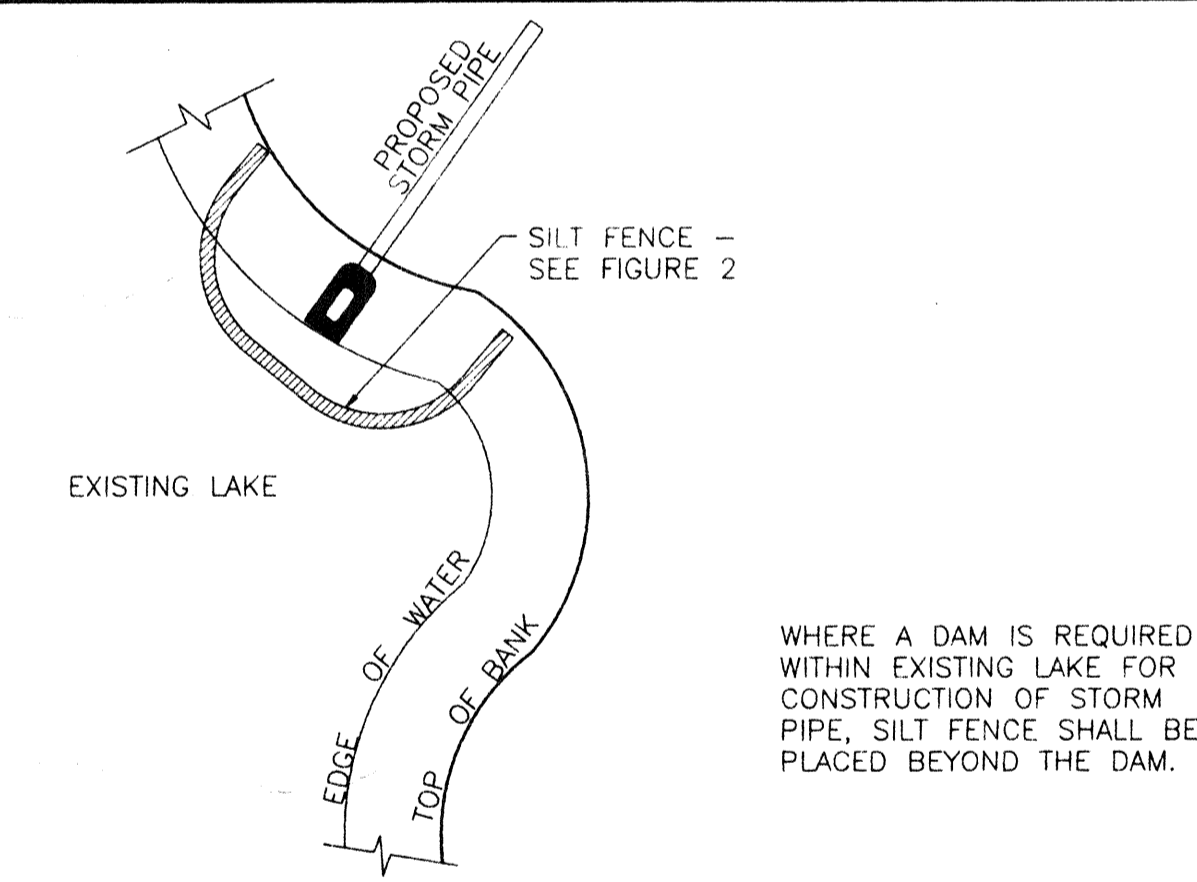

SILT BARRIER AT CONNECTION OF
STORM PIPE TO EXISTING LAKE
N.T.S.

FIGURE 9

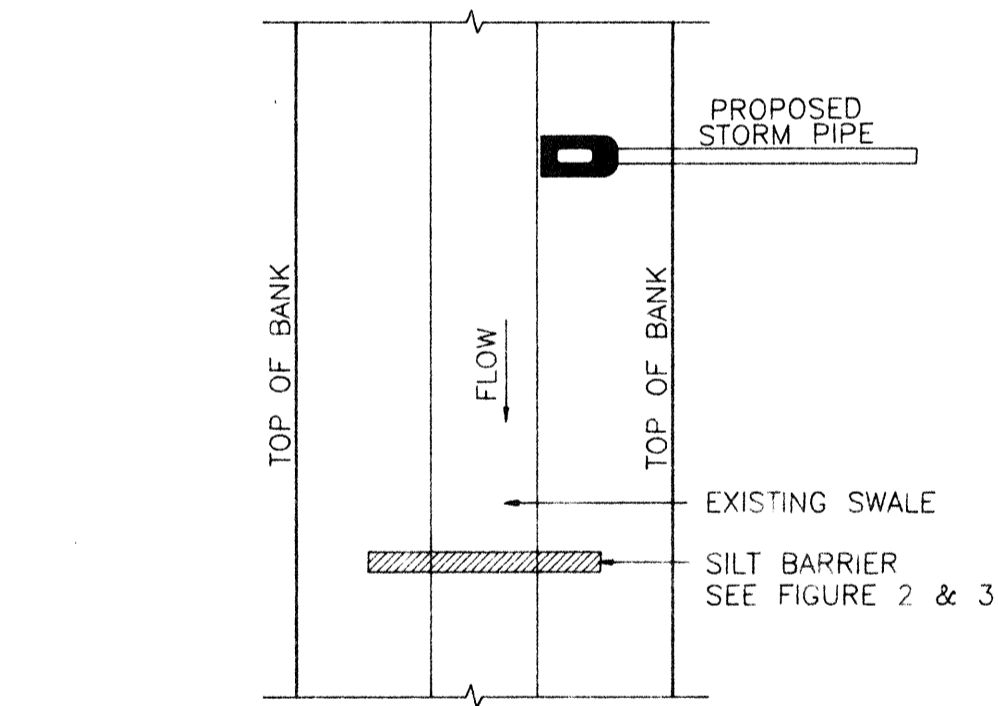

SILT BARRIER AT CONNECTION
OF STORM PIPE TO EXISTING SWALE
N.T.S.

FIGURE 10

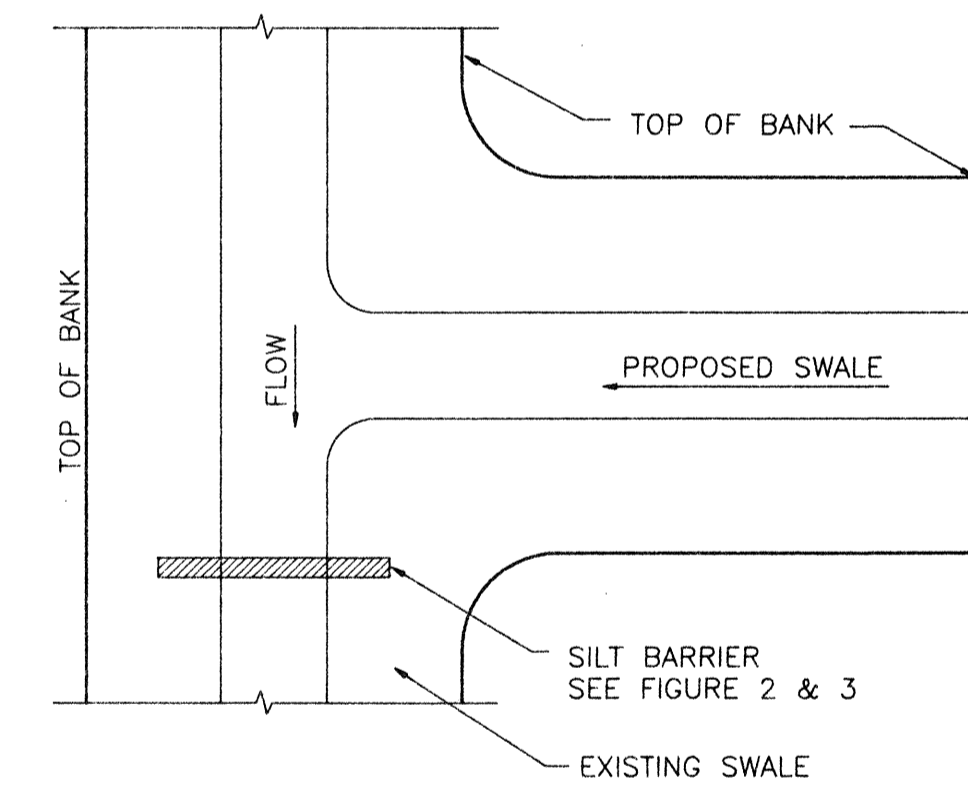

SILT BARRIER AT CONNECTION
OF SWALE TO EXISTING SWALE
N.T.S.

FIGURE 11

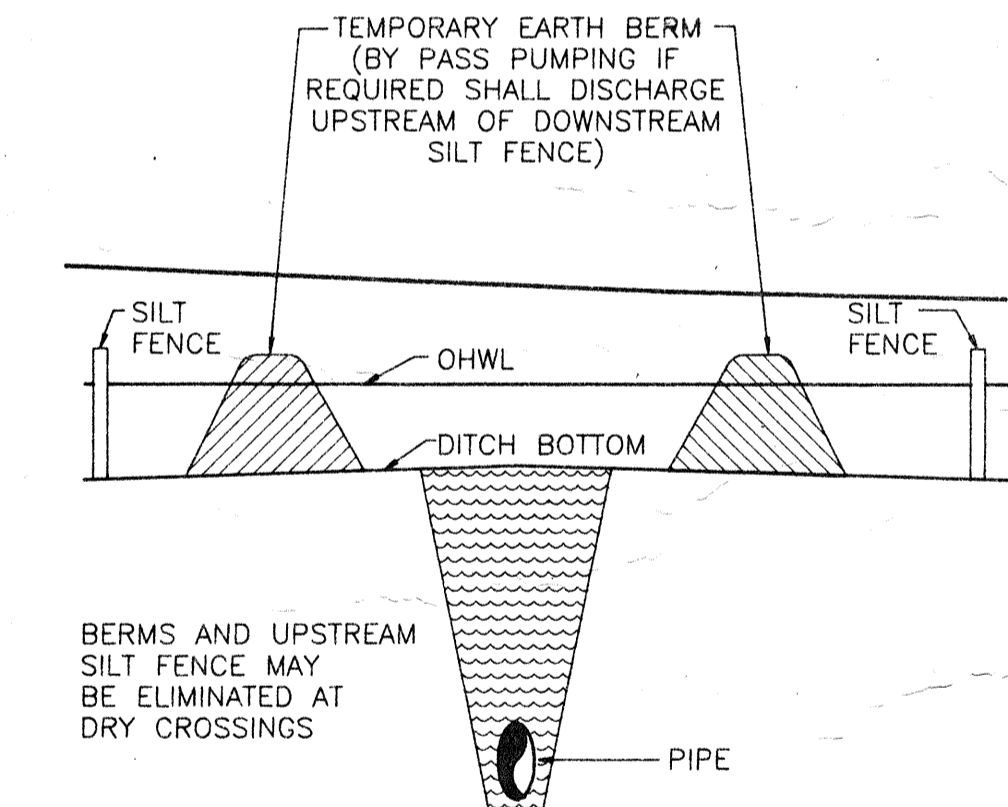

UNDERGROUND PIPE CROSSINGS

FIGURE 12

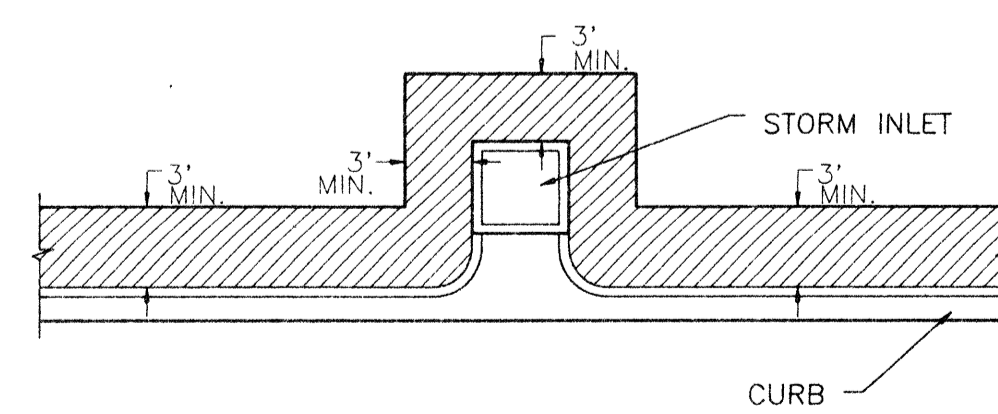

SOD ALONG CURB
AND AROUND INLET
N.T.S.

FIGURE 13

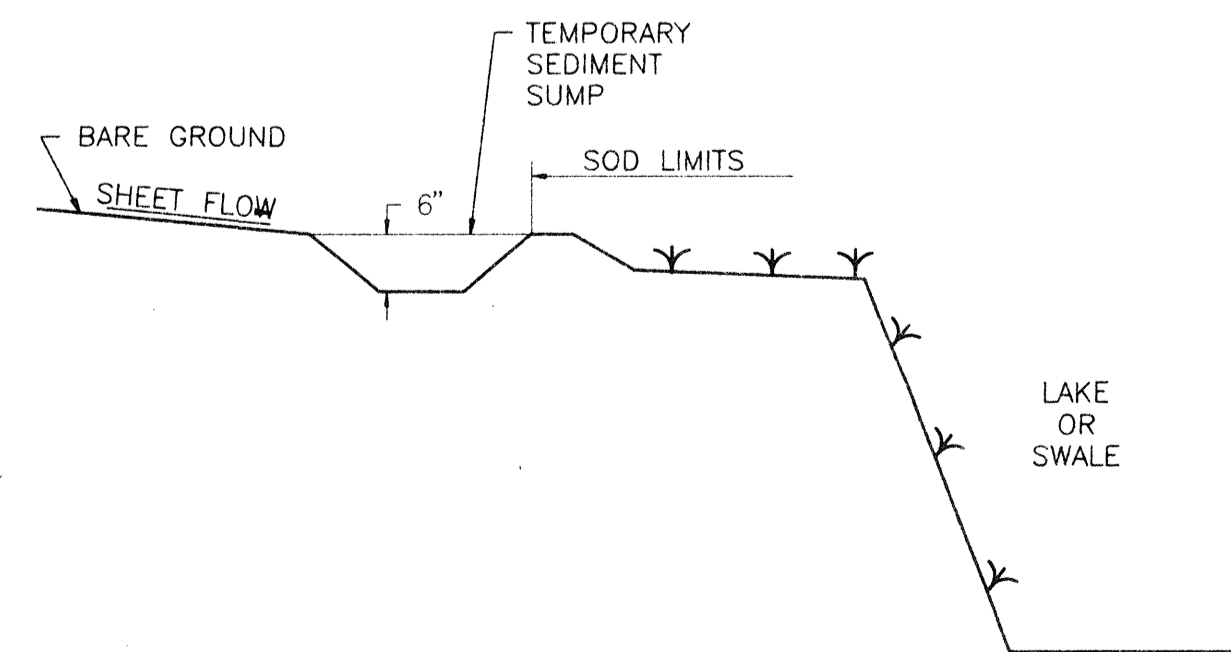

TEMPORARY SEDIMENT
SUMP
N.T.S.

FIGURE 14

BEST
MANAGEMENT
PRACTICES

MINDER & RHODES ENGINEERING CORPORATION
 Engineers - Planners - Surveyors
 3900 CLARK ROAD
 SARASOTA, FL 34233
 P.E. No. 111492
 Date 11/14/92
 P.O. No. 111492
 CAD DWG. No. 111492

APPROVED
 [Signature]
 Date 08/03/93

DESIGNED
 [Signature]
 Date 08/03/93

CHECKED
 [Signature]
 Date 08/03/93

SCALE
 N/A

DRAWN
 [Signature]
 Date 08/03/93

REVISIONS

No.	Date	By	Descriptions

REGENT COURT
 REGENT COURT GROUP/BOWYER DEVELOPMENT CORP.
 LONGBOAT KEY, FLORIDA
 SARASOTA COUNTY

BEST MANAGEMENT PRACTICES