

TYPICAL METERED SERVICE DETAILS
NO SCALE

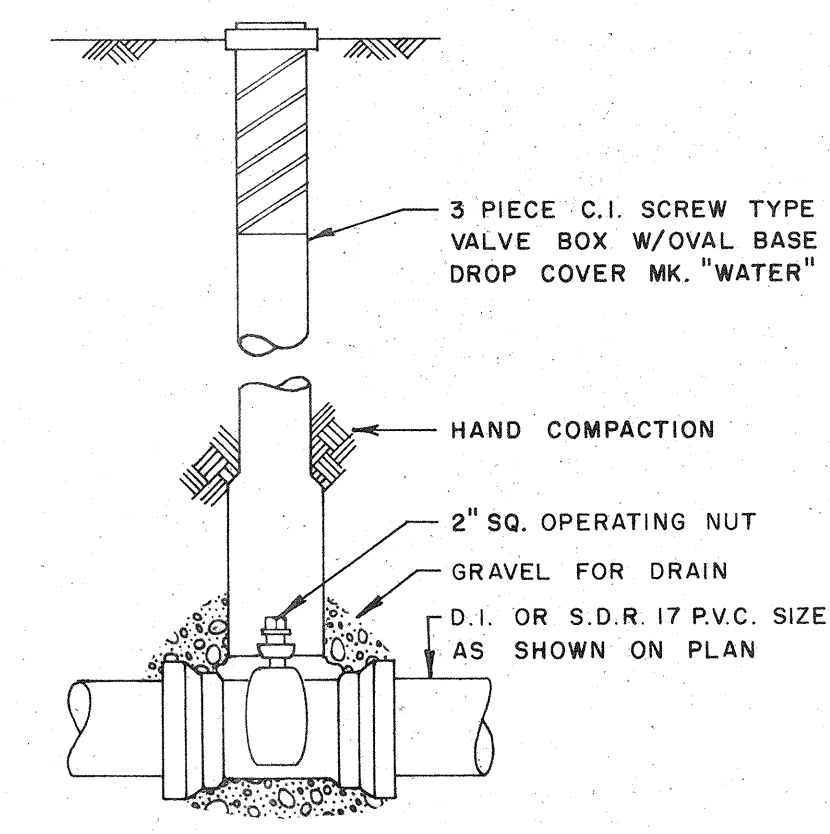

VALVE DETAIL
NO SCALE

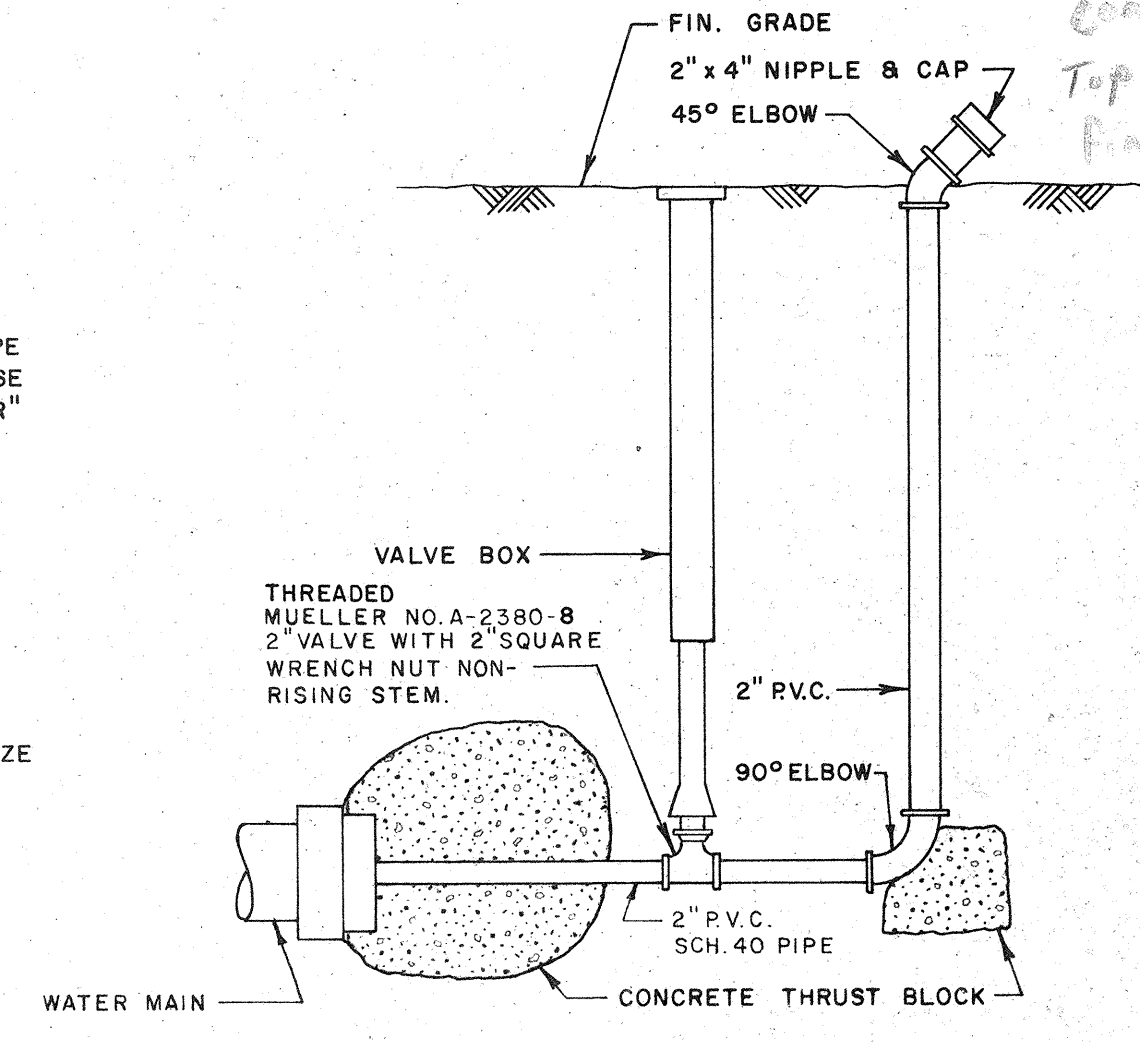

TYPICAL BLOWOFF DETAIL
NO SCALE

Enclose Blow off in a concrete meter box. Top of box even with finished grade.

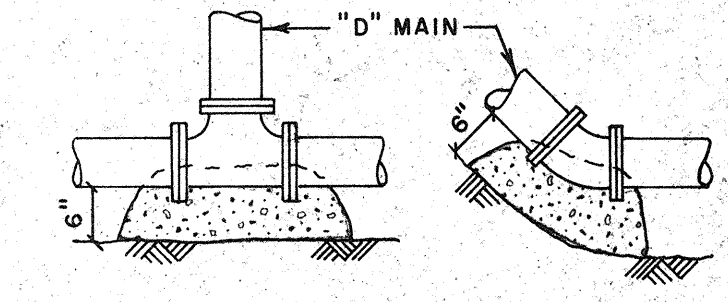

AREAS DETERMINED BY CONC. CONTACT WITH UNDISTURBED MATERIAL

THRUST BLOCK AREAS IN SQ. FT.				
SIZE	TEE	90° BEND	45° BEND	22 1/2° BEND
4"	1.5	2.0	1.0	1.0
6"	4.0	5.5	3.0	1.5
8"	7.0	10.0	5.0	3.0
10"	10.0	14.0	7.0	5.0

WATER MAIN THRUST BLOCKS

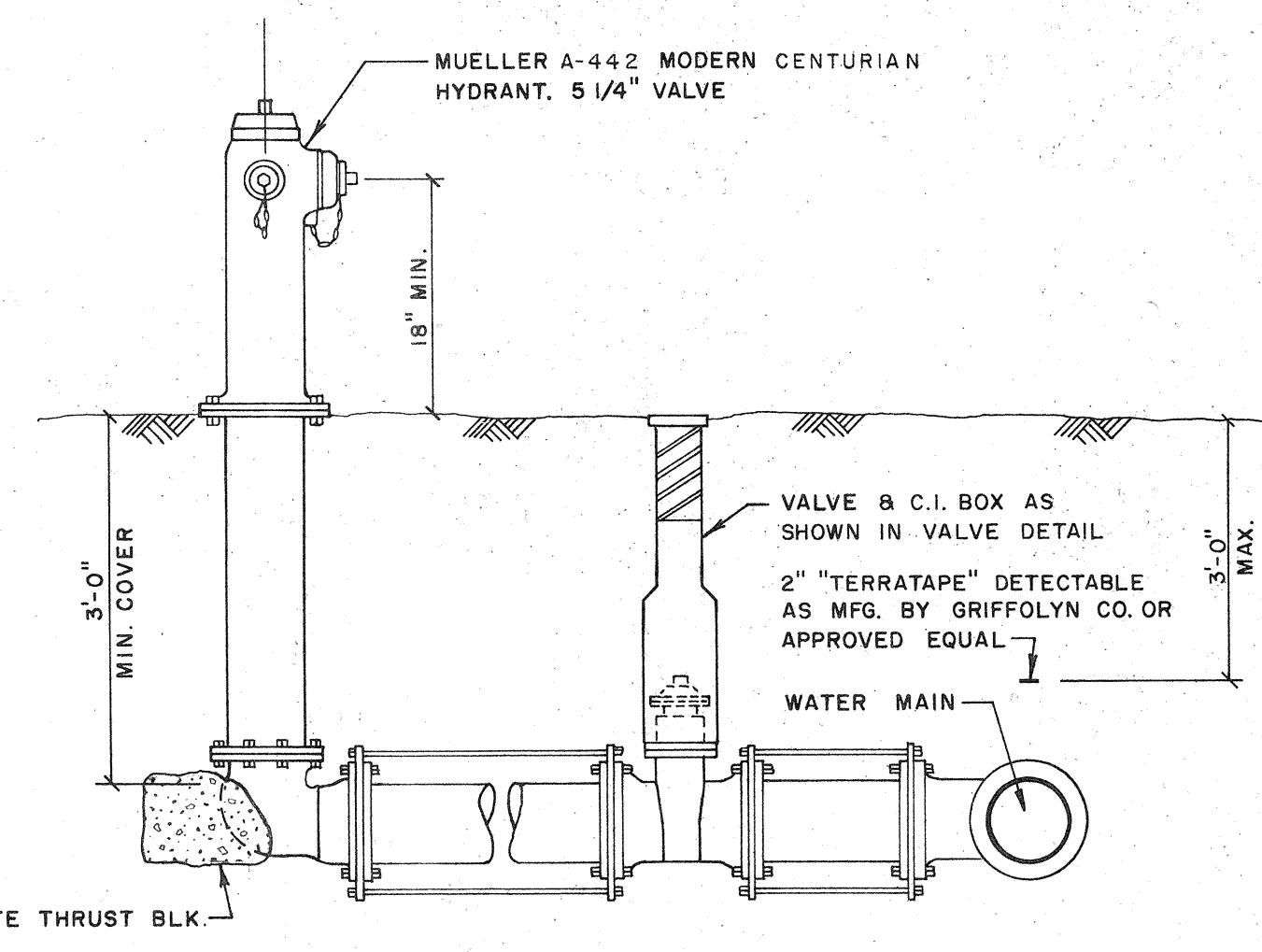

TYPICAL FIRE HYDRANT DETAIL
NO SCALE

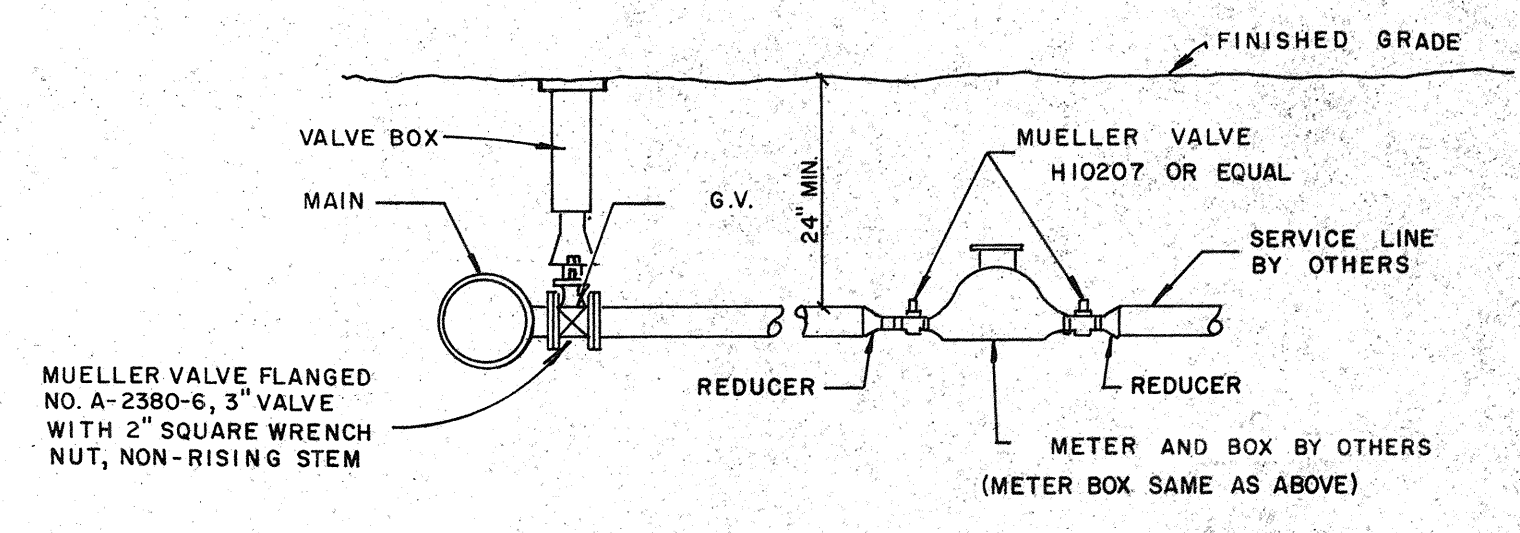

TYPICAL SERVICE DETAIL
NO SCALE

NOTE
1. ALL P.V.C. WATER MAIN SHALL BE COLOR CODED BLUE WITH CLASSIFICATION SDR-17, WITH 36" COVER AND DETECTABLE TAPE

P. WALLEBERG DEVELOPMENT CO. INC.
SANDHAMM

WATER SUPPLY DETAILS

DRAWG. NO. 297-009

DATE: 1-30-85

REVISION: 1

DESCRIPTION: REV. TYP. SERVICE DET. & TYP. BLOWOFF DET.

BY: [Signature]

APPROVED: [Signature]

CONSULTING ENGINEERS & SURVEYORS

BENNETT & BISHOP

FLORIDA

SARASOTA