

## MEMORANDUM

**TO:** Howard Tipton, Town Manager

**From:** Allen Parsons, AICP  
Director, Planning, Zoning & Building Department

**Report Date:** November 22, 2024

**Meeting Date:** December 2, 2024

**Subject:** Appeal Petition of Administrative Shoreline Construction Departure Denial at 592 Ranger Lane

### **Recommended Action**

Deny the Appeal Petition of Administrative Shoreline Construction Departure Denial at 592 Ranger Lane, continue the quasi-judicial hearing to the Town Commission's January 6, 2025 Regular Meeting, and instruct the Town Attorney to prepare an appropriate Order of Denial for the Town Commission's consideration at the January 6, 2025 Regular Meeting.

### **Background**

Pursuant to Town Code Section 151.07, the property owner (Michael J. Leone) of 592 Ranger Lane (Parcel ID No. 0009160031) is appealing an administrative Shoreline Construction Departure denial, which was received on August 14, 2024.

The requested Departure was sought for a new corrugated seawall that has been partially constructed, in front of (waterward) an existing concrete seawall, with a total width of 27.25 inches. This width is 15.25 inches greater than allowed by Town Code Sec. 151.03(B)(3)(a), which provides for the "...replacement of existing seawalls within an existing subdivision or developed area...as follows:"

***"Construction, inclusive of a buttress and seawall cap, shall not protrude more than 12 inches seaward of the existing seawall or seawall cap. Notwithstanding the foregoing, if there are two existing seawalls abutting the subject replacement seawall of differing seaward projections, then the subject replacement seawall shall be further limited to a seaward projection distance of no more than either equal to the immediately abutting seawall with the least projection or a total seaward projection of 12 inches, whichever is less."***

The denial of the requested Departure contains staff's assessment (Attachment B) of the request and a relevant history of the building permit application for the seawall at the subject property.

In addition to the staff assessment, contained in the Departure denial letter of August 14, 2024, the Town Commission's packet (Attachment D) includes a Memorandum from the Town Attorney that addresses the subject of, "Equitable Estoppel Principles in Land Use/Permitting Matters."

### **Staff Recommendation**

Deny the Appeal Petition of Administrative Shoreline Construction Departure Denial at 592 Ranger Lane, continue the quasi-judicial hearing to the Town

Commission's January 6, 2025 Regular Meeting, and instruct the Town Attorney to prepare an appropriate Order of Denial for the Town Commission's consideration at the January 6, 2025 Regular Meeting.

**Attachments**

- A. Email Correspondence from Michael and Karen Leone (592 Ranger Lane property owners) indicating that they are not represented by Bentley Goodrich Kison, P.A., November 22, 2024
- B. Applicant's Appeal Petition Request, September 19, 2024, including Applicant's Departure Request, June 28, 2024
- C. Applicant's Supplemental Memorandum, November 20, 2024
- D. Administrative Appeal Denial, August 14, 2024
- E. Town Attorney Memorandum Re: Equitable Estoppel Principles in Land Use/Permitting Matters, September 18, 2024
- F. Correspondence from the Public

Attachment 'A'

**From:** [Michael Leone](#)  
**To:** [Allen Parsons](#)  
**Cc:** [Bobby Halliday](#); [Morgan Bentley](#); [Cori Coser](#); [Maggie Mooney-Portale](#); [Town Clerk](#); [Karen Leone](#)  
**Subject:** Re: 582/592 Ranger Lane Appeal of Departure Request denial - Supplemental Memorandum  
**Date:** Friday, November 22, 2024 2:03:53 PM  
**Attachments:** [Seawall\\_email\\_6-12-24\\_No\\_Legal\\_Representaton.pdf](#)  
[Halliday\\_Seawall\\_Letter\\_PDF2.pdf](#)  
[image002.png](#)  
[image003.png](#)  
[Supplemental\\_Memorandum\\_582&592\\_Ranger\\_Lane\\_Appeal\\_of\\_Departure\\_Request\\_Denial.pdf](#)  
[2\\_582\\_Ranger\\_Lane\\_Legal\\_Notice.pdf](#)  
[2\\_592\\_Ranger\\_Lane\\_Legal\\_Notice.pdf](#)

---

**This Message Is From an Untrusted Sender**

You have not previously corresponded with this sender.

[Report Suspicious](#)

Hello Allen,

In response to the email from Cori Coser from Bentley Goodrich Kison, P.A. dated November 20, 2024 it is important that we clarify our position on the matter of the seawall at 582/592 Ranger Lane, Longboat Key.

I am the owner of 592 Ranger Lane, and with my wife Karen, full-time residents of Longboat Key. As we have discussed in the past, we have not been party to any written contract, financial obligation, or verbal agreements with either Florida Shoreline and Foundation, or Bentley Goodrich Kison, P.A. Attached is a copy of an email dated June 12, 2024, in reply to Morgan Bentley in which we stated we would not be represented by their legal counsel.

We are a neutral party to this project/process. Pending the decision of Longboat Key Town Commission, we would like to state our expectation. It is a reasonable expectation that if approved, our portion of the seawall project would be completed with a cap by the owners of 582 Ranger Lane and Florida Shoreline and Foundation OR if denied, our portion of the seawall would be remediated and rebuilt/returned to Longboat Key building code by the same parties mentioned above. Additionally, if the seawall variance is approved, it is a reasonable expectation that we would receive a variance from The Town of Longboat Key to ensure that we have no non-conforming violations for our property.

Although the seawall construction at 582 Ranger Lane extended 32” onto our property at 592 Ranger Lane, we were not party to the contract, design, execution or financial commitment of this project. We do not support any failure to comply with town code.

Again, we are not represented, by Bentley Goodrich Kison, P.A., as they have stated in their letter to you dated November 20, 2024, nor do we hold the position they have outlined in this letter as we have not been party to the contract, design or construction process between Bobby Halliday and Florida Shoreline and Foundation. Please share this information with the Longboat Key Town Commission so that they are aware of these details.

Respectfully,  
Michael & Karen Leone  
630-302-1600

On Nov 20, 2024, at 5:23 PM, Cori Coser <ccoser@bgk.law> wrote:

Good afternoon Mr. Leone,

Please see the attached memorandum filed this afternoon. As a reminder, the public hearing is on December 2, 2024 at 1:00pm. I have attached the meeting notices as well which give more information.

Let me know if you have any questions. Thanks!

|



BENTLEY GOODRICH KISON P.A. 2022  
RECOGNIZED BY  
**Best Lawyers®**

Cori S. Coser, Esq.  
Bentley Goodrich Kison, P.A.  
Main: (941) 556-9030  
Fax: (941) 312-5316  
[ccoser@bgk.law](mailto:ccoser@bgk.law)  
783 South Orange Ave.  
Third Floor  
Sarasota, Florida 34236  
[www.bgk.law](http://www.bgk.law)



---

**From:** Cori Coser  
**Sent:** Wednesday, November 20, 2024 5:18 PM  
**To:** Allen Parsons <[AParsons@longboatkey.org](mailto:AParsons@longboatkey.org)>  
**Cc:** Maggie Mooney-Portale <[mmooney@swflgovlaw.com](mailto:mmooney@swflgovlaw.com)>; Town Clerk <[TClerk@longboatkey.org](mailto:TClerk@longboatkey.org)>; Morgan Bentley <[mbentley@bgk.law](mailto:mbentley@bgk.law)>  
**Subject:** 582/592 Ranger Lane Appeal of Departure Request denial - Supplemental Memorandum

Good Afternoon Mr. Parsons,

As you are aware, this firm represents the Applicants with regard to the Appeal of the Departure Request denial relating to 582 Ranger Lane and 592 Ranger Lane. Please accept this supplemental memorandum in support of their position.

Please do not hesitate to contact me if you have any questions. Thank you!

|

|

Cori S. Coser, Esq.  
Bentley Goodrich Kison, P.A.  
Main: (941) 556-9030  
Fax: (941) 312-5316  
[ccoser@bgk.law](mailto:ccoser@bgk.law)  
783 South Orange Ave.  
Third Floor  
Sarasota, Florida 34236  
[www.bgk.law](http://www.bgk.law)



**From:** Michael Leone <[mikeleone62@gmail.com](mailto:mikeleone62@gmail.com)>

**Sent:** Wednesday, June 12, 2024 9:59 AM

**To:** Morgan Bentley <[mbentley@bgk.law](mailto:mbentley@bgk.law)>; Bobby Halliday <[bobby@bobbyhalliday.co.uk](mailto:bobby@bobbyhalliday.co.uk)>

**Cc:** Bruce franklin <[bfranklin@srqplanning.com](mailto:bfranklin@srqplanning.com)>; Karen Leone <[leone174@me.com](mailto:leone174@me.com)>

**Subject:** Re: seawall

Hello Bobby, Morgan and Bruce,

It seems that Karen and I are being pulled into a situation much further than is necessary. As your abutting neighbor we were never partner to the seawall design, construction or payment agreement between yourself (Bobby Halliday) and Florida Shoreline. Consequently, it is unclear why we would need representation by Morgan Bentley (Florida Shoreline legal counsel).

Attached is the letter we provided outlining our position regarding your seawall at 582 Ranger Lane. This letter was omitted from your variance application packet.

We were in agreement with the original construction to include the 32" into our property line since the construction of our wall (completed previous to us owning the property) stopped short of the wall at 582 Ranger. This was done so as not to cause an issue for your failing seawall. We assumed that the seawall built by Florida Shoreline would be built to code as outlined in my letter below and in the permit submitted by Florida Shoreline to Longboat Key.

As you know, Bobby and Bruce requested that we sign a variance application to include our 32" portion of the wall so that, if approved, the variance would allow for construction to be completed on the entire wall. The only reason we signed the variance application was to assist you in getting this completed.

**We do not need to be represented by any legal counsel as we were not party to the original design, construction, financial payment or decisions made regarding this seawall.**

We wish you well with the variance application. If by chance it is denied, we are confirming as you and I have discussed (Bobby), that we have no financial obligation to correct any portion of the wall that is out of code, as we were not part of the original contract or any decisions made with Florida Shoreline.

Best regards,

Michael & Karen Leone

Michael and Karen Leone  
592 Ranger Lane  
Longboat Key, FL 34228

June 2, 2024

Bobby and Jacqueline Halliday  
582 Ranger Lane  
Longboat Key, FL 34228

Dear Bobby and Jacqueline,

As per your request, we are writing in support of your seawall construction at 582 Ranger Lane, Lot 7, Block C, Country Club Shores. Our understanding is that the seawall construction completed by Florida Shoreline and Foundation was built 28" seaward of the existing seawall (with code and permits allowing for 12" seaward extension). As we both know and have agreed, we have a particular interest in the seawall being built to code and/or being approved with a variance by the Town of Longboat Key since 32" of this seawall crosses onto our property (592 Ranger Lane, Lot 6, Block C, Country Club Shores).

Again, we have no objection to the seawall construction that has been completed on your property. We also understood that the seawall construction would extend onto our property by 32" and be built to code. As you seek a variance for the seawall construction that has been completed, we want to be sure that if/when approved, this variance covers the entirety of the wall which spans both of our properties (Lot 7 & Lot 6, Block C, Country Club Shores).

As a property owner on Longboat Key, Karen and I want to be sure that any construction on our property is done to code, and therefore creating no future negative impact for our property.

We sincerely hope that you can get this accomplished so that your seawall construction can be completed.

Sincerely,

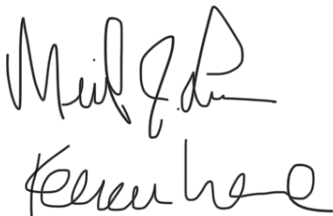
The image shows two handwritten signatures in black ink. The top signature is 'Michael Leone' and the bottom signature is 'Karen Leone'. Both are written in a cursive, flowing style.

Michael and Karen Leone

Please note, here is historical information regarding why 32" of your seawall construction falls on our property.

*As we understand (we did not own the property at the time), several years ago when the contractor replaced the seawall at 592 Ranger Lane, Lot 6, Block C, Country Club Shores, they were forced to stop short of the property line so as not to jeopardize the integrity of your adjacent failing seawall.*

Attachment 'B'



**Town of Longboat Key  
Planning, Zoning and Building Department**

501 Bay Isles Road  
Longboat Key, Florida 34228  
941-316-1966  
941-316-1970 FAX

**AMENDED**

**APPEAL OF DECISION OF AN ADMINISTRATIVE OFFICIAL**

Application must be completed in its entirety, and owner's signature notarized.

**APPLICANT IS REQUIRED TO SUBMIT THIRTEEN (13) INDIVIDUAL, COLLATED SETS OF THIS APPLICATION, SUPPORTING PLANS AND DOCUMENTS ALONG WITH ONE (1) DIGITAL COPY OF ALL MATERIALS.**

**APPLICATION FEE: \$1,000.00 deposit**

(Application fee of \$450.00 will be deducted from deposit)

At the conclusion of your plan review by the Town, you will be billed for additional staff time, Town Attorney cost, cost of advertising, and any other miscellaneous costs incurred with the processing of your application(s). Costs will be deducted from initial deposit. If costs exceed the initial deposit, you will be billed for the remaining costs incurred; or you will be refunded the unused portion of the deposit.

**OFFICE USE ONLY:**

Date Filed: \_\_\_\_\_ Receipt No. \_\_\_\_\_ Petition# \_\_\_\_\_

**APPEAL REQUEST:**

( I ) (We) Morgan Bentley, Esq. on behalf of Robert Halliday and Michael Leone

Mailing Address 582 Ranger Lane & 592 Ranger Lane

City: Longboat Key State: Florida Zip: 34228

Request that a determination be made by the (check one) Town Commission  Zoning Board of Adjustment

of the Town of Longboat Key on the following appeal from the ruling of an Administrative Official made on August 14 2024.

This appeal concerns Section(s) 151.03, \_\_\_\_\_, \_\_\_\_\_,  
Paragraph(s) (E), (B)(3)(a) of the Town of Longboat Key Code of Ordinances.

Subject property is located at: 582 Ranger Lane, Longboat Key, Florida 34228 & 592 Ranger Lane, Longboat Key, Florida 34228

The legal description is as follows: Lot(s) \_\_\_\_\_ Block \_\_\_\_\_

Subdivision or Plat: \_\_\_\_\_

Or LOT 7 BLK C COUNTRY CLUB SHORES UNIT 4 & LOT 6 BLK C COUNTRY CLUB SHORES UNIT 4  
(if otherwise legally described)

**PROPERTY DESCRIPTION:**

Lot Size: 10,013 sq. ft. Present Zoning Classification: R4SF Present Use: Single Family Detached

Present Structure(s) type and improvements upon the land: Home, pool, and seawall.

If this appeal is granted, the effect will be to: complete construction of the seawall on the property.

(I) (We) believe that the appeal should be granted because (state below the grounds for the administrative appeal; use additional sheets if necessary): Please see attach ed.

LIST OF NAMES AND ADDRESSES OF ALL OWNERS OF PROPERTY WITHIN A DISTANCE OF 500 FEET FROM THE OUTSIDE EDGES OF THE PROPERTY INVOLVED WILL BE PROVIDED BY THE TOWN.

**SIGNATURE OF PROPERTY OWNER(S)/AGENT**

(I) (WE) understand that this document becomes a part of the permanent records of the Town of Longboat Key. (I) (WE) hereby certify that the above statements and the statements or showings made in any paper or plans submitted herein are true to the best of (my) (our) knowledge and belief.

Signature of Owner [Signature]  
Printed/Typed Name of Owner Robert Halliday (Robert Halliday)  
Phone: 941-553-9030 Email: mbentley@bgk.law  
Mailing Address: 783 South Orange Avenue, Suite 300  
City: Sarasota State: Florida Zip: 34236

In addition to Owner's signature, please complete this section if the owner designates an agent to act on their behalf in regard to this appeal:

Signature of Agent [Signature]  
Printed/Typed Name of Agent Morgan Bentley, Esq. (Morgan Bentley, Esq.)  
Company/Firm: Bentley Goodrich Kison, P.A.  
Phone: 941-553-9030 Email: mbentley@bgk.law  
Mailing Address: 783 South Orange Avenue, Suite 300  
City: Sarasota State: Florida Zip: 34236

**NOTARIZATION OF OWNER'S SIGNATURE**

State of Florida  
County of Sarasota

The foregoing instrument was acknowledged before me by means of physical presence  or online notarization , this 11th day of September 2024

By Robert Halliday  
Signature of Notary Public [Signature]  
Printed/Stamped Name of Notary Public Deborah R. Woodson

Personally known  OR produced identification  Type of ID: U.K. Driver's License

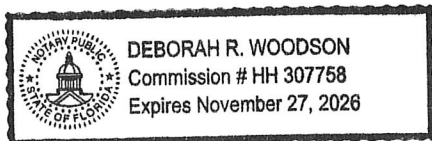

(I) (We) believe that the appeal should be granted because (state below the grounds for the administrative appeal; use additional sheets if necessary): Please see attached.

LIST OF NAMES AND ADDRESSES OF ALL OWNERS OF PROPERTY WITHIN A DISTANCE OF 500 FEET FROM THE OUTSIDE EDGES OF THE PROPERTY INVOLVED WILL BE PROVIDED BY THE TOWN.

**SIGNATURE OF PROPERTY OWNER(S)/AGENT**

(I) (WE) understand that this document becomes a part of the permanent records of the Town of Longboat Key. (I) (WE) hereby certify that the above statements and the statements or showings made in any paper or plans submitted herein are true to the best of (my) (our) knowledge and belief.

Signature of Owner *Michael Leone*

Printed/Typed Name of Owner Michael Leone

Phone: 941-553-9030 Email: mbentley@bgk.law

Mailing Address: 783 South Orange Avenue, Suite 300

City: Sarasota State: Florida Zip: 34236

In addition to Owner's signature, please complete this section if the owner designates an agent to act on their behalf in regard to this appeal:

Signature of Agent *Morgan Bentley*

Printed/Typed Name of Agent Morgan Bentley, Esq.

Company/Firm: Bentley Goodrich Kison, P.A.

Phone: 941-553-9030 Email: mbentley@bgk.law

Mailing Address: 783 South Orange Avenue, Suite 300

City: Sarasota State: Florida Zip: 34236

**NOTARIZATION OF OWNER'S SIGNATURE**

State of Florida  
County of Sarasota

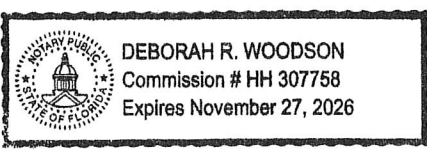

The foregoing instrument was acknowledged before me by means of physical presence  or online

notarization  this 17<sup>th</sup> day of September 2024

By Michael Leone

Signature of Notary Public *Deborah R. Woodson*

Printed/Stamped Name of Notary Public Deborah R. Woodson

Personally known  OR produced identification  Type of ID: Florida Driver's License



A COMMERCIAL LITIGATION LAW FIRM

**MORGAN R. BENTLEY**  
*Managing Shareholder*  
*Board Certified Business Litigation*

**BRIAN D. GOODRICH**  
*Shareholder*

**AMANDA R. KISON**  
*Shareholder*  
*Board Certified Business Litigation*

**CAROLEEN B. BREJ**

**CORINNA S. COSER**

**KATLYN N. CRAIG**

**ASHLEY E. GAILLARD**

**KAYLIN M. HUMERICKHOUSE**

**MADLINE A. SALAMONE**

**DAVID A. WALLACE**  
*Board Certified Appellate Law*  
*and Fla. Certified Mediator*

August 19, 2024

**VIA: US Mail & Email: [aparsons@longboatkey.com](mailto:aparsons@longboatkey.com)**

Allen Parsons, Director  
Town of Longboat Key  
Planning, Zoning and Building Department  
501 Bay Isles Road  
Longboat Key, Florida 34228

**RE: Appeal of Denial of Shoreline Construction Departure Request  
582 & 592 Ranger Lane**

Dear Mr. Parsons,

This Firm represents Bobby Halliday, the owner of 582 Ranger Lane (“Property”), and Florida Shoreline and Foundation, the contractor for the seawall project at the Property (collectively, the “Applicant”) with regard to the August 14, 2024, denial of the Departure Request for the seawall construction at the Property (the “Denial”).

The seawall at the Property is in severe condition and is in need of immediate replacement. The initial plan was to remove the pin piles and install new sheet panels immediately in front of the existing wall. Upon mobilization to the site and further inspection of the seawall, the Applicant discovered that the concrete panels were cracked and broken, with the pin piles being the only structure keeping the seawall in place. To prevent wall failure into the canal, and preserve the upland, the Applicant submitted the Departure Request on June 28, 2024, which kept the pin piles in place and extended the seawall past the existing seawall no more than 12 inches. This Departure Request was denied on August 14, 2024.

Pursuant to the Town of Longboat Key Code Section 151.07, the Applicant hereby petitions the Town Commission for review of the Denial. The new seawall has no negative effect on the neighbors or on navigation. However, without approval, significant damage will result to the Property, the canal itself, and likely the adjoining properties.

Please do not hesitate to contact me with any questions.

Sincerely,

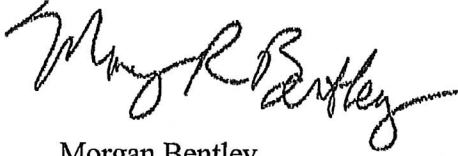
A handwritten signature in black ink, appearing to read "Morgan Bentley". The signature is fluid and cursive, with a long horizontal flourish extending to the right.

Morgan Bentley  
For the Firm

cc: Town Commission  
Bobby Halliday  
Florida Shoreline and Foundation  
Bruce Franklin





June 28, 2024

Mr. Allen Parsons, Director  
Planning, Zoning, & Building Dept.  
Town of Longboat Key  
501 Bay Isles Road  
Longboat Key, FL 34228

Re: Departure request for Seawall Construction – 582 & 592 Ranger Lane – Permit No. PB23-0253

Dear Allen;

I am writing as Agent for Mr. Robert Halliday, Owner of 582 Ranger Lane (PID No. 0010-02-9998) Mr. Michael J. Leone, TTEE, Owner of 592 Ranger Lane (PID No. 0009-16-0031) to submit a request for Departure from the Zoning Code. As you know this project was proceeding under a valid and proper building permit (See attached permit No. PB23-0253) for 582 Ranger Lane issued by the Town. The construction extended 32 inches onto the Leone property, at their request, in order to close the gap between the Leone's cap and seawall and their neighbor's (Halliday). Nobody considered another permit was needed.

Following receipt of a complaint a stop-work order was issued on May 13, 2024, citing a violation of Section 151.B.3.a of the Town Code as follows:

3.) The repair or replacement of existing seawalls within an existing subdivision or developed area shall be permitted as follows:

- a.) Construction, inclusive of a buttress and seawall cap, shall not protrude more than 12 inches seaward of the existing seawall or seawall cap. Notwithstanding the foregoing, if there are two existing seawalls abutting the subject replacement seawall of differing seaward projections, then the subject replacement seawall shall be further limited to a seaward projection distance of no more than either equal to the immediately abutting seawall with the least projection or a total seaward projection of 12 inches, whichever is less.

This request is for a departure of 15.25 "(27.25" – 12" = 15.25").

The existing wall was constructed around 60 years ago when Country Club Shores was developed. The seawall design/construction at the time was inadequate to stand the test of time and somewhere around 1999 wooden 'pinpilings' were installed to stabilize the failing wall panels without a permit which was a common

Mr. Allen Parsons, Director

June 28, 2024

Page 2

practice all over Country Club Shores, according to the contractor. In this case the contractor for the new seawall was aware of the pinpilings and assumed they would remove them once construction began as they have been able to do in other instances. However, when they mobilized, they found the existing wall panels to be in such defective condition they had the Engineer evaluate the installation and he determined that the pinpilings could not be removed as they were integral to the existing seawall system, structurally, and if removed, the wall would completely fail, and the upland yard and pool would slide into the canal. Therefore, the contractor submitted revised plans and a letter of explanation, with the Engineer's certification, to your Department showing the pinpilings remaining and the new wall installation not to exceed 12" from them (See attached Exhibits). (Note; The dimensions of the pinpilings was not shown because they varied between 8" and 10" and meandered along the length of the existing wall rendering a consistent measurement impossible. Additionally, the pinpilings were not evenly spaced and therefore could not be located within the corrugated configuration of the new wall form.)

The revised permit drawings were approved by Building on April 12, 2024, and by Zoning on April 19, 2024. Notwithstanding the general note on the permit of the Zoning Code Section 151 B.3.a. cited above, the wall section provided with the May 9 letter clearly shows the "neighbor's sea wall panel", the Halliday failed wall, the pinpilings and the maximum 12" for the new wall, as do the actual revised stamped, approved permit drawings. Thereafter, construction continued in good faith and in reliance until a complaint was filed and your Department issued a stop-work order. The project sits at 90% complete with only the seawall cap to be poured and landscaping to be installed. See attached photographs of the current condition. Also see the plan view drawing dated revised 6/17/24 showing the 32" dimension of the wall and cap extending onto the Leone property. Again, notwithstanding there is a condition noted on the permit requiring compliance with Section 153.B.3.a., the contractor assumed that the construction pursuant to the approved permit was in all ways compliant. He had no reason to believe otherwise.

This existing installation system is not isolated, is common throughout the Longboat canals and should be considered as the "existing wall" (Wall panel + pinpiling) when applying Section 151.B.3.a. To be honest, it is also in the public interest since, if old walls were to fail, not only would there be significant impacts on adjacent property owners, but also establish a precedent for variances having to be filed, administrative/delay costs, Town enforcement, potential litigation, etc. Furthermore, we have documented numerous instances on Longboat of new seawall construction which exceeds the 12" threshold yet which were permitted, presumably (one of them is currently under construction). I have suggested the Town consider simply determining the existing installation, including the pinpilings, defines the "existing wall" from which the 12' dimension is to be measured.

You have indicated you have the administrative authority to grant a departure pursuant to the following:

*151.03 - Permit required; application.*

*(E) Any request for a departure from the requirements of this Code, or any dispute as to structural integrity of any structure proposed under this Code, shall be resolved by the town manager or designee. Any expertise necessary to assist the town manager or designee in*

Mr. Allen Parsons, Director

June 28, 2024

Page 3

*making that decision shall be at the applicant's expense. In making the determination as to whether to grant a departure, the town manager or designee must determine that the proposed design meets the intent of this chapter*

So, the contractor issued revised plans effectively requesting the Town for a 'departure' from the code and was, effectively, granted the 'departure' (The Building Department is a designee of the Town Manager) by stamping the revised plans approved on April 12, and 19, 2024. If you and Patti are not authorized to grant such approval, how was the contractor to know that? Although not technically a request for departure, the submittal of the revised plans effectively amounted to departure request from the cited Code section. Upon resubmittal your staff, evidently, asked some clarifying questions of the contractor, granted the approval and construction continued until the stop-work order was issued.

If the Town had denied the revised plans to install the new wall in front of the existing pin piles before construction began, a request for a departure or variance would have been applied for at that time. Approval of the revised plans indicated a variance was not required or that a 'departure' had been granted administratively. Evidently, the Town changed its position, or has recognized they improperly approved the plans placing an undue burden on the property owners, now necessitating this request. We recognize an after-the-fact permit application is required for 592 Ranger Lane and that will be forthcoming. Additionally, please apply the prior Variance Application filing fees to the costs associated with this request.

Allen, I believe the foregoing and materials included provide you with the information required to process this request. Also attached is the filing fee of \$1,000.00. If upon receipt you require anything additional, please do not hesitate to contact me. Thank you very much for your assistance.

Sincerely,

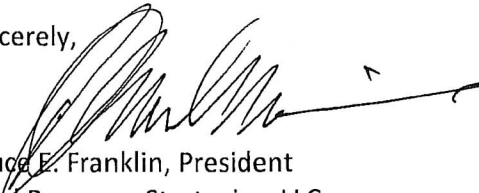

Bruce E. Franklin, President  
Land Resource Strategies, LLC

cc: Morgan Bentley, Esq.



# PERMIT

PERMIT NUMBER:  
**PB23-0253**

PERMIT TYPE:  
**BUILDING -  
DOCK/SEAWA  
LL/LIFT**

**ISSUED: 04/20/2023**

**ADDRESS: 582 RANGER LN**

USE: RESIDENTIAL

**WORK DESCRIPTION: INSTALL NEW SEAWALL**

OWNER: HALLIDAY ROBERT

CONTRACTOR: Florida Shoreline & Foundation Experts LLC

CONTRACTOR PHONE: (941) 927 1410 LICENSE: CBCI 260841

STIPULATIONS: Seawall construction height shall not exceed a maximum height of 4.5-foot elevation (NAVD 1988) inclusive of the seawall cap.

Construction, inclusive of a buttress and seawall cap, shall not protrude more than 12 inches seaward of the existing seawall or seawall cap. Notwithstanding the foregoing, if there are two existing seawalls abutting the subject replacement seawall of differing seaward projections, then the subject replacement seawall shall be further limited to a seaward projection distance of no more than either equal to the immediately abutting seawall with the least projection or a total seaward projection of 12 inches, whichever is less.

*Note: Contractors/owners please contact your community association prior to start of any work.*

IT IS THE RESPONSIBILITY OF PERMIT HOLDERS OF EACH PHASE OF WORK TO PROCURE INSPECTIONS AS REQUESTED AND TO VERIFY APPROVALS PRIOR TO PROCEEDING TO NEXT PHASE.

## INSPECTIONS:

Building - Dock/Seawall/Lift Inspections (PERMIT REQUIRED)				
Permit Number:				
TYPE	STATUS	INSPECTOR	DATE	COMMENTS
Tieback Anchor/Deadman				
NPDES				
Cap Steel				
Final Building				
Other				

NOTICE (Fla. Statute 553.79(10)): In addition to the requirements of this permit, there may be additional restrictions applicable to this property that may be found in the public records of the county, and there may be additional permits required from this or other governmental entities such as water management districts, state or federal agencies.

PERMITS FOR DEMOLITIONS OR RENOVATIONS OF AN EXISTING STRUCTURE: This is notification of the owners or owner's representative's responsibility to comply with provisions of s. 469.003 Florida Statutes printed below, regarding Asbestos Abatement and to notify the Department of Environmental Protection of your intentions to remove asbestos, when applicable, in accordance with the state and federal law.

F.S. 469, Asbestos Abatement. 469.003 License Required

- (1) No person may conduct an asbestos survey, develop an operation and maintenance plan, or monitor and evaluate asbestos abatement unless trained and licensed as an asbestos consultant as required by this chapter.
- (2) No person may prepare asbestos abatement specifications unless trained and licensed as an asbestos consultant as required by this chapter.
- (3) No person may contact the department under this chapter as an asbestos contractor, except as otherwise provided in this chapter.

~~WARNING TO OWNER: YOUR FAILURE TO RECORD A NOTICE OF COMMENCEMENT MAY RESULT IN YOUR PAYING TWICE FOR IMPROVEMENTS TO YOUR PROPERTY. IF YOU INTEND TO OBTAIN FINANCING, CONSULT WITH YOUR LENDER OR AN ATTORNEY BEFORE RECORDING YOUR NOTICE OF COMMENCEMENT.~~

**130.02(C) Unreasonable Sound Prohibited**

(2)(f) Construction and demolition. Engaging in construction or demolition on Sunday, on any holiday, or between the hours of 5:00 p.m. and 8:00 a.m. Monday through Saturday except for emergency work by a public service utility or by other permit approved by the town. This sub section shall not apply to the use of domestic power tools as specified in subsection (i) of this section.

**PARKING INFORMATION**

*For properties along Gulf of Mexico Drive:*

Parking along the entire length of Gulf of Mexico Drive is prohibited. Vehicles that are parked along either side of Gulf of Mexico Drive are subject to a \$75 parking citation.

*For properties in the Village:*

Service Vehicles (a "vehicle with a business sign or logo owned and operated by a person, firm or corporation actively engaged in a service or business activity at the home of Resident within the Resident-Only Parking Permit area") can park on Village streets that allow Resident-Only Parking. Service vehicles are encouraged to use Resident-Only spaces rather than parking in the limited publicly available parking spaces.

**PERMIT MUST BE POSTED IN A CONSPICUOUS LOCATION VIEWABLE FROM ROAD.  
INSPECTION REQUESTS REQUIRED AT LEAST 24 HOURS IN ADVANCE.  
REQUESTS: 941-316-1966**

Town of Longboat Key - Planning, Zoning & Building - 501 Bny Isles Road, Longboat Key, FL 34228 - 941-316-1966 F: 941-316-1970

RECEIVED  
Date of Payment by  
Planning, zoning & Building  
5/23/2017 1:29:00 AM

# Sarasota County Property Appraiser

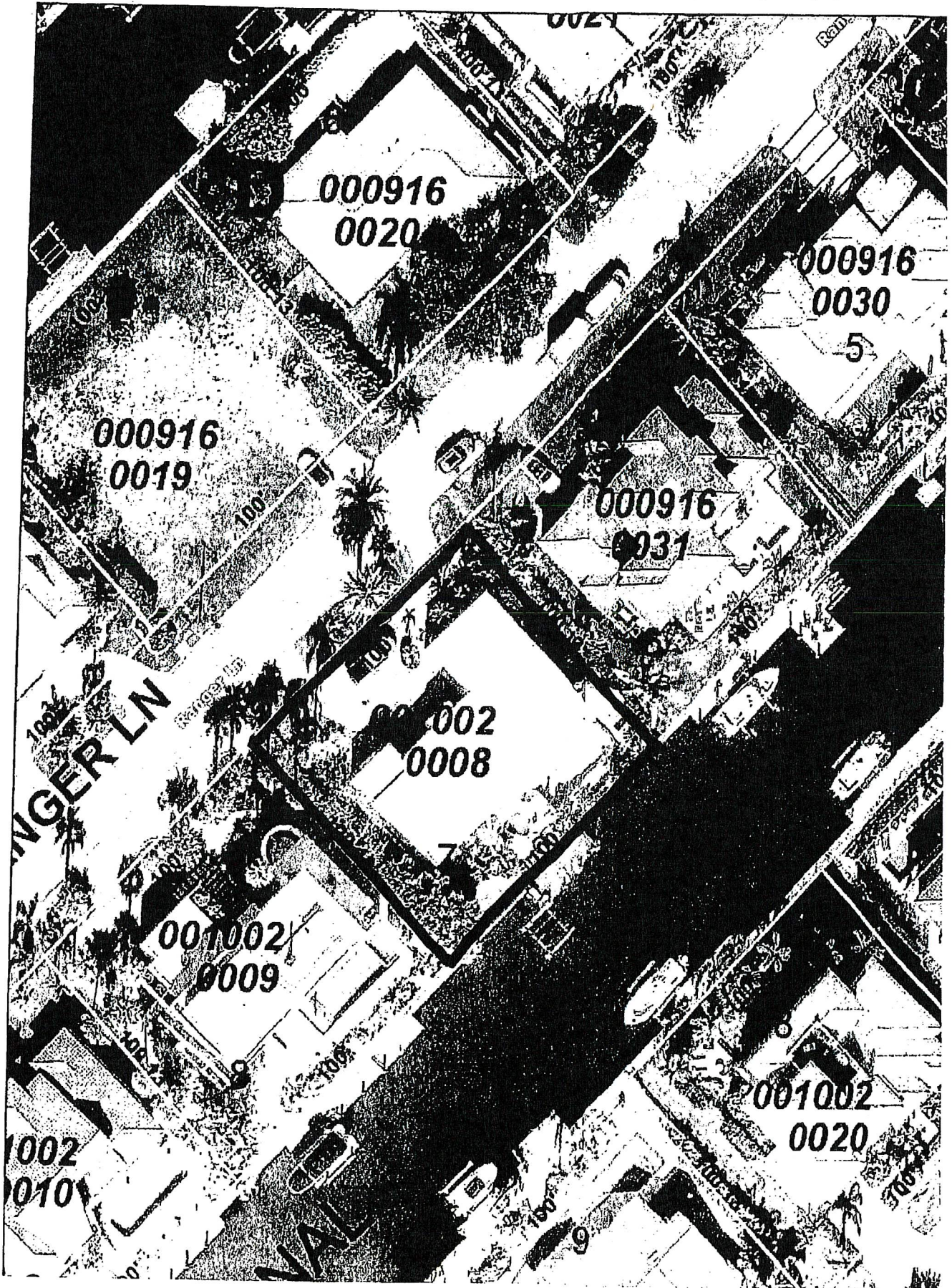

Halliday 100' +/-

Legend  
📍 582 Ranger Ln

RECEIVED  
From: [unreadable]  
To: [unreadable]  
Date: [unreadable]

582 Ranger Ln

Google Earth

© 2010 Google

704

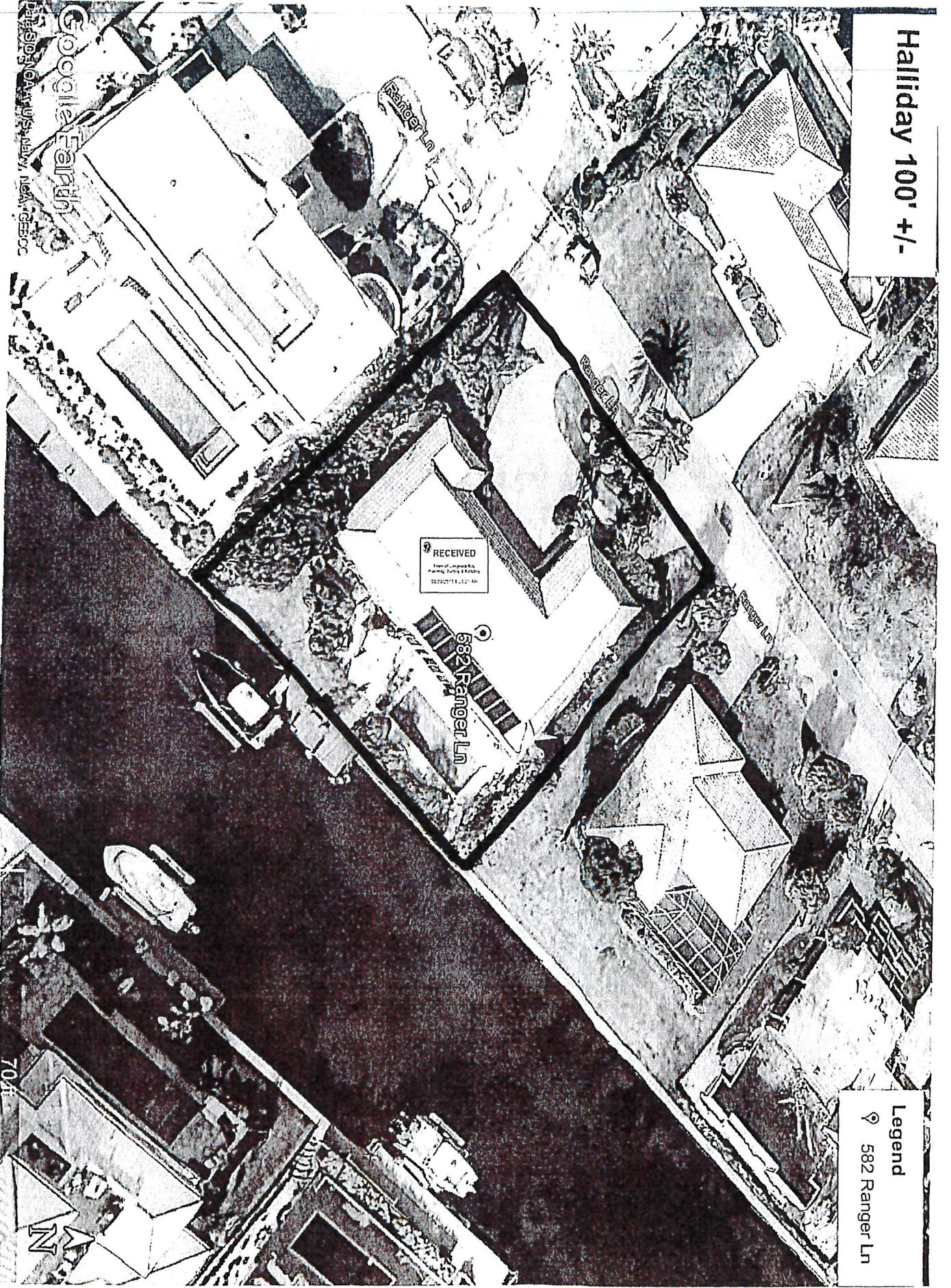

NOTE: MANTA-RAY OPTION SHOWN.  
DEADMAN ANCHORS TO BE USED AS REQUIRED.

MANTA-RAY ANCHORS

NOTE: EXISTING TIMBER PIN PILES TO REMAIN. PROPOSED WALL TO BE INSTALLED DIRECTLY IN FRONT OF PIN PILES.

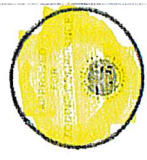

1/19/2024 7:05:57 PM  
PB23-0253  
Jonathan Taylor

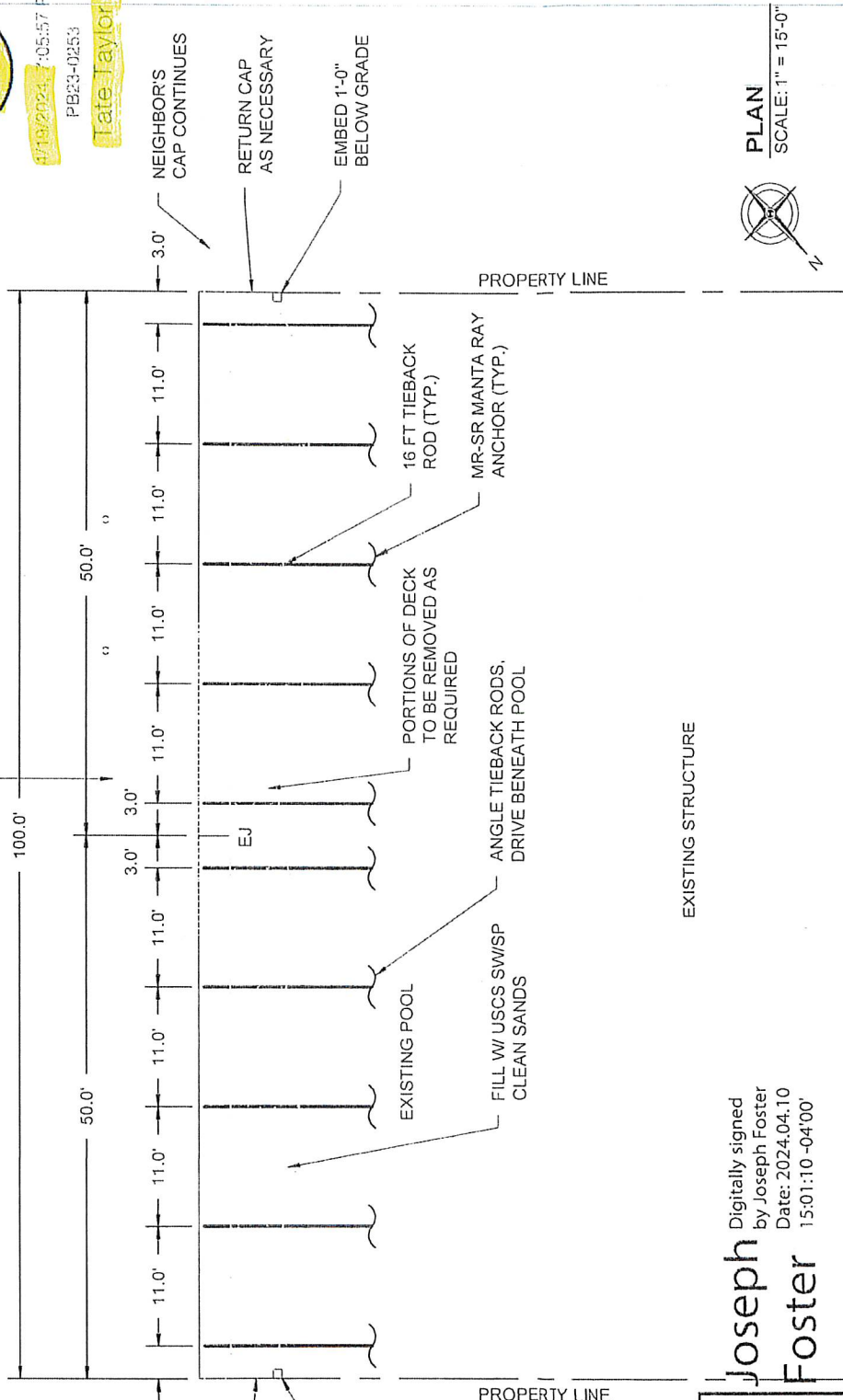

Joseph Foster  
Digitally signed  
by Joseph Foster  
Date: 2024.04.10  
15:01:10 -04'00'

PLAN  
SCALE: 1" = 15'-0"  
N

NOT VALID UNLESS SIGNED & SEALED

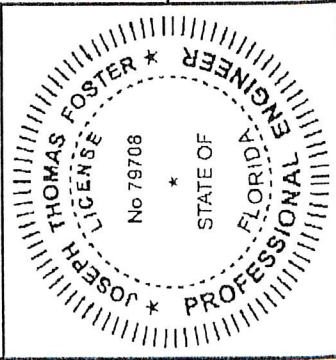

**FOSTER CONSULTING**  
FL PROFESSIONAL ENGINEER NO. 79708  
DE LIC. # 18618 - NJ LIC. # 24GED05181200 - TX LIC. # 133648  
FL CERTIFICATE OF AUTHORIZATION NO. 32050  
WWW.JFOSTERCONSULTING.COM  
P: (727) 821-1949  
P.O. BOX 7370, ST. PETERSBURG, FL 33734

DATE:	03/15/23	FILE:	23092
DRAWN BY:	SIP	SHEET:	01 OF 02
CHECKED BY:	JTF	SCALE:	AS NOTED
582 RANGER LN LONGBOAT KEY, FLORIDA		SEAWALL PLAN	
		01	



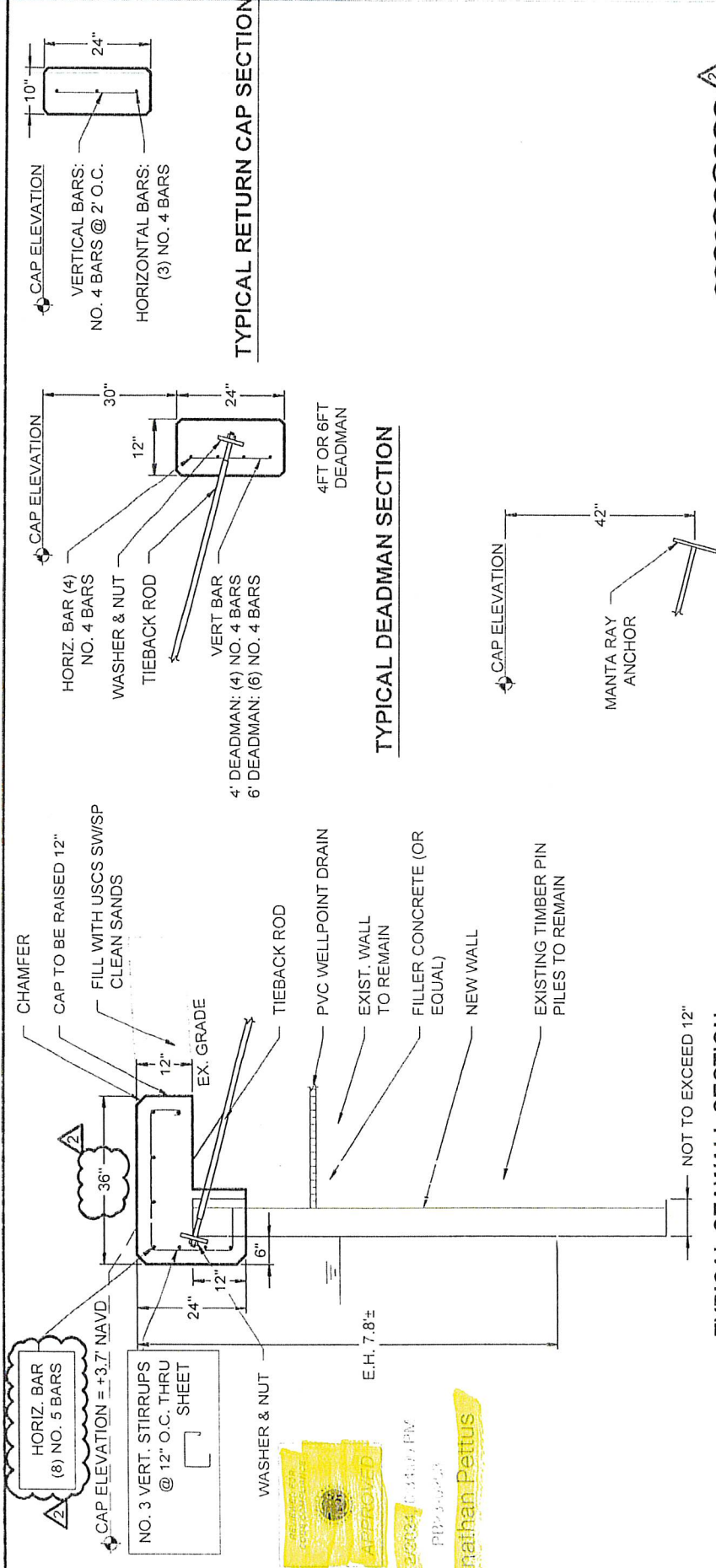

REVISION 2: 04/10/2024

Joseph Foster  
Digitally signed by Joseph Foster  
Date: 2024.04.10 15:01:25 -04'00'

NOT VALID UNLESS SIGNED & SEALED

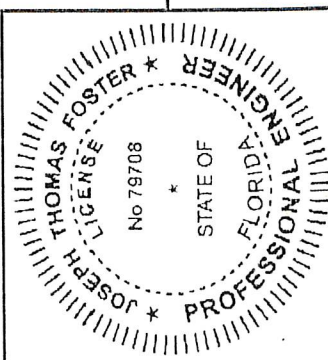

**CONSTRUCTION NOTES:**

1. CONCRETE - 5000 PSI (CAP) & 3500 PSI (FILLER) AT 28 DAYS
2. SHEETS - 14 FT LONG VINYL SHEET PILE (CL - 9900, ESP 6-5, SG - 550, TW - 70, TRULINE\*, OR VANGUARD STD). \*TRULINE CONTACT E.O.R FOR ADDITIONAL SPECS.
3. TIEBACK RODS - 1" x 16 FT PVC ENCASED TIEBACK ROD WITH (2) HDG 6" x 6" x 1/2" PLATE WASHERS & NUTS AT EACH END WITH CONCRETE DEADMAN OR 1" x 16 FT HDG TIEBACK ROD W/ (1) HDG PLATE WASHER & NUT CONNECTED TO MR-SR MANTA RAY ANCHORS TENSIONED TO 13000#.
4. REBAR - GRADE 60, PLAIN.
5. DRAINS - 1.25" DIA. X 4FT LONG SLIT TYPE PVC WELL POINT DRAINS THROUGH BOTH WALLS AT 6' CENTERS 6" ABOVE THE BARNACLE LINE.
6. MEETS FBC 2020 - 7TH EDITION

**FOSTER CONSULTING**  
FL PROFESSIONAL ENGINEER NO. 79708  
DE LIC. # 18618 - NJ LIC. # 24GE05181200 - TX LIC. # 133648  
FL CERTIFICATE OF AUTHORIZATION NO. 32050  
[WWW.JFOSTERCONSULTING.COM](http://WWW.JFOSTERCONSULTING.COM)  
P: (727) 821-1949  
P.O. BOX 7370, ST. PETERSBURG, FL 33734

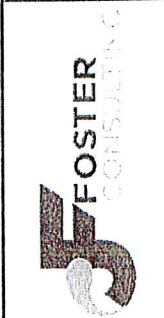

DATE:	03/15/23	FILE:	23092	REV:	2
DRAWN BY:	SIP	SHEET:	02 OF 02		
CHECKED BY:	JTF				
SCALE:	AS NOTED				
582 RANGER LN LONGBOAT KEY, FLORIDA					
<b>SECTIONS</b>					
		<b>02</b>			



May 9, 2024

Mr Tate Taylor  
Town of Longboat Key

**Re: 582 Ranger Lane, Permit #PB23-0253**

Dear Mr. Taylor

As discussed, please accept this letter as a follow up to our discussion regarding the construction of the new seawall at 582 Ranger Lane, and an explanation of what existed before we began work and what the end result will be.

The seawall at 582 Ranger Lane is an original concrete seawall which was constructed approximately 60+ years ago. Some time after the initial construction, wood "pinpilings" were installed in front of the existing wall. These pinpiles were installed in front of seawalls which were experiencing rotation of the panels due to not enough panel embedment into the canal (a common problem in Country Club Shores). Many of these pin piles were installed before I started in the marine construction industry in 1999 so I estimate the pilings at 582 Ranger Lane were installed pre-1999. The pinpiles became an integral part of the seawalls. Without the pinpiles many seawalls in Country Club Shores, including this one, would have failed long ago. To prevent the need for pinpilings, new sheet panel seawalls are constructed with 40% or more of the panel length embedded into the canal bottom.

When we applied for the permit to build the new wall at 582 Ranger Lane the initial plan was to remove the pinpiles and install the new sheet panels immediately in front of the existing wall. Upon mobilization to the site and further inspection of the wall it was discovered just how bad of condition the wall was in. The concrete panels were cracked and broken. The only thing keeping the wall in place and vertical was the pinpiles. Removal of the pinpiles would most certainly result in immediate failure of the seawall, and due to the close proximity of the pool, the pool would suffer significant damage as well. Foster Consulting prepared a letter summarizing the issues, followed by engineered plans showing the pinpiles to remain and the new panels to be no more than 12" waterward of these piles.

4561 Clark Road • Sarasota, FL 34233 • 941.927.1410 • [shorelineandfoundation.com](http://shorelineandfoundation.com)

CBC1260841 • SCC131151783



The new seawall at 582 Ranger Lane will not have any negative affect to the neighbors nor to navigation, and I believe meets the plans submitted. Without the approval of the pin piles staying in place, it would have resulted in significant and unnecessary damage to this property and most probably the adjoining properties as well. Attached is a sketch showing in more detail the dimensions of the wall in relation to the neighboring wall to the east.

I hope this helps clarify what is being built and why it is being built the way it is. If you have any questions please do not hesitate to call.

Respectfully submitted,

A handwritten signature in black ink, appearing to be 'Scott Liebel', written over a horizontal line.

Scott Liebel  
Florida Shoreline and Foundation

February 2<sup>nd</sup>, 2024

Florida Shoreline & Foundation  
4561 Clark Rd.  
Sarasota, FL 34233

Re: Seawall replacement at 582 Ranger Ln. Longboat Key, FL 34228

To Whom It May Concern,

The seawall at the subject property is in severe condition and is in need of replacement. The concrete panels have buckled near the mudline and are kicking out waterward. Timber pin piles were installed at some time in the past in an effort to stabilize the wall. Removal of the pin piles may allow the wall to fail completely, allowing the upland sediment to displace into the water, decreasing water quality in the canal. Furthermore, a failure of the wall, or removal of the failed concrete slabs, would put the upland structures, including the pool, at severe risk of damage and movement. For these reasons, it is recommended to install the new vinyl seawall panels waterward of the timber pin piles to prevent a wall failure and preserve the upland.

If there are any questions, please call. Thank you for the opportunity to be of service.

Sincerely,

Foster Consulting

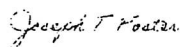

Joseph T. Foster, P.E.

FL Lic No. 79708  
NJ Lic No. 24GE05181200  
DE Lic No. 18618

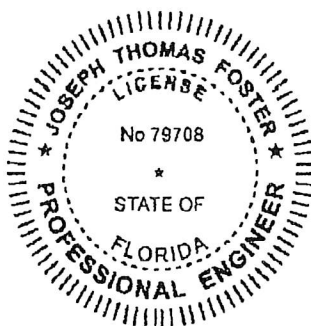

Joseph  
Foster

Digitally signed  
by Joseph  
Foster  
Date:  
2024.02.02  
09:39:05 -05'00'

Prepared By: Florida Shoreline and Foundation  
4561 Clark Rd., Sarasota, FL 34233  
www.shorelineandfoundation.com  
941-927-1410 CBC 1260841



Scale: 3/8" = 1'  
Date:  
May 9, 2024

# 582 Ranger Lane

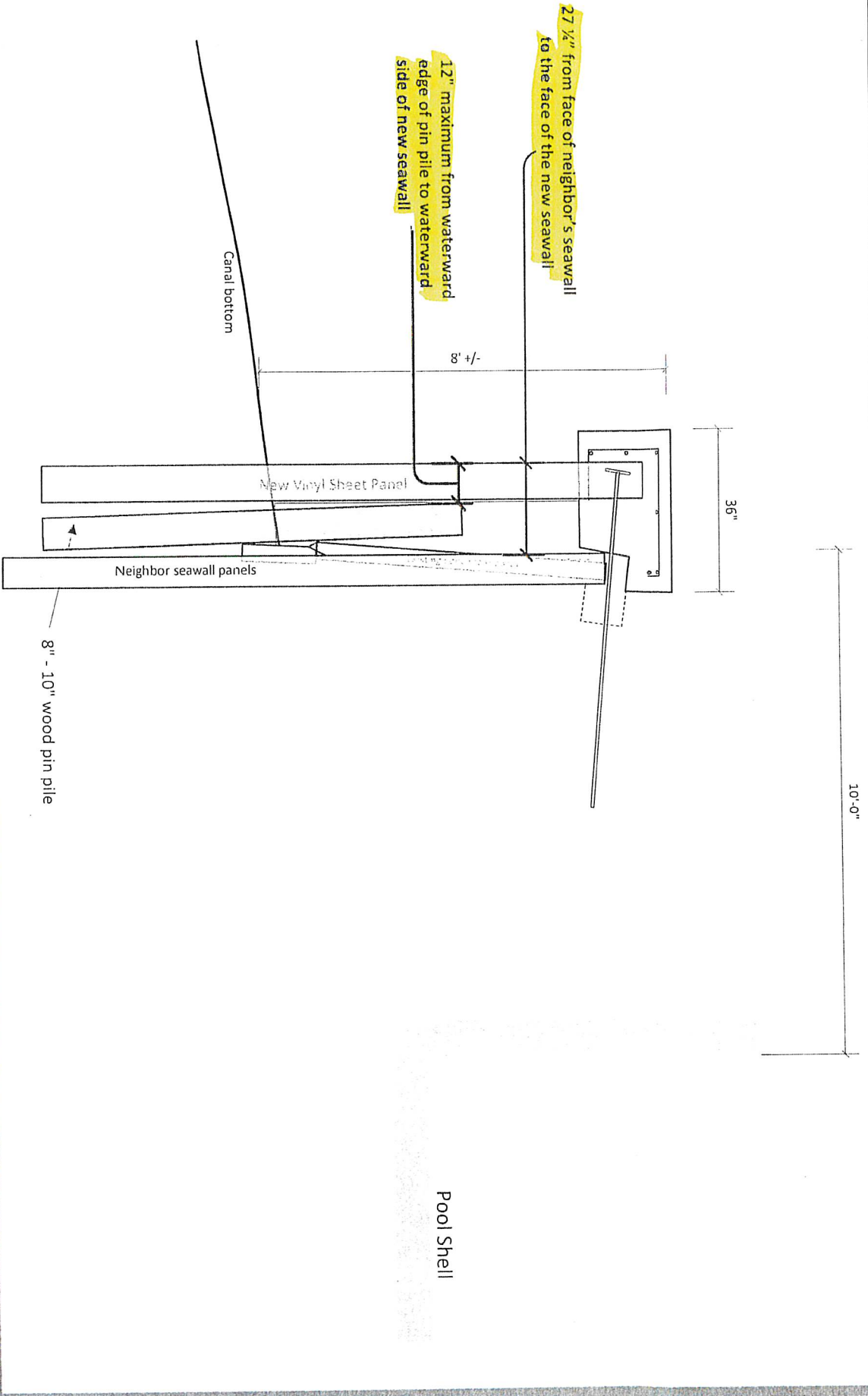

---

Rich and Marsha Kolb  
572 Ranger Ln  
Longboat Key, FL 34228

June 3, 2024

Bobby and Jacqueline Halliday  
582 Ranger Lane  
Longboat Key, FL 34228

Dear Bobby and Jacqueline,

We have been following the construction of your new seawall very closely since it began. We have done so visually as well as through the Town's permitting website (reviewing submitted documents). We have also had conversations with your contractor to ensure that the work being done will only impact the stability of our seawall positively. We are confident that the work being done is of a high quality and will protect you and your neighbors as intended. We hope that the seawall can be completed as soon as possible.

We are very upset that the town has halted construction. With hurricane season approaching we feel much less secure with an unfinished wall. Requiring removal of your wall would further risk the stability of our wall as well as your other neighbor's wall and is unacceptable.

It is also strange that documents that we had previously viewed, which approved placement of the wall, are no longer visible on the website.

We have also heard that the HOA has indicated that you need approval to complete the seawall. We know of at least 3 seawalls on Ranger Ln. that proceeded without HOA approval and that the HOA specifically was not reviewing plans for seawalls in the past. We hope that the HOA is not selectively enforcing its rules and regulations in this situation.

We are happy to assist you in any way to expedite the completion of this seawall.

Very truly yours,

Rich and Marsha Kolb

Cc: Bruce Franklin

June 2, 2024

Bobby and Jacqueline Halliday  
582 Ranger Lane  
Longboat Key, FL 34228

Dear Bobby and Jacqueline,

We have been watching the construction progress of your new seawall diagonally across the canal from us, and were surprised and perplexed to learn that the project had been stopped when it is essentially completed except for pouring the concrete cap. Our understanding is that the project, after an initial redesign to address the problem with the exiting pinpiles, had been submitted, approved, and permitted by the Town of Longboat Key and was being built to current code requirements.

As we look along our canal's seawalls, no two walls are the same because they were rebuilt at different times by different contractors and perhaps slightly different building codes. There are differences in the width and height of the seawalls and their vertical members and caps. One of the seawalls abutting our property, installed just last year, is 8-9 inches higher than ours or our neighbors on our other side. The structural integrity of all seawalls along the canal are important to every property owner, and the fact that yours is being constructed fully to code requirements satisfies any of our concerns. Your seawall looks just fine from our perspective across the canal.

In short, we support the completion of your seawall project without reservation and hope it can be finished without further delay.

Sincerely,



Rodney A. Erickson

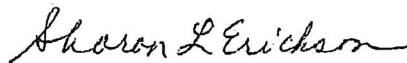

Sharon L. Erickson  
573 Halyard Lane  
Longboat Key FL 34228

Cc: Bruce Franklin

Michael and Karen Leone  
592 Ranger Lane  
Longboat Key, FL 34228

June 2, 2024

Bobby and Jacqueline Halliday  
582 Ranger Lane  
Longboat Key, FL 34228

Dear Bobby and Jacqueline,

As per your request, we are writing in support of your seawall construction at 582 Ranger Lane, Lot 7, Block C, Country Club Shores. Our understanding is that the seawall construction completed by Florida Shoreline and Foundation was built 28" seaward of the existing seawall (with code and permits allowing for 12" seaward extension). As we both know and have agreed, we have a particular interest in the seawall being built to code and/or being approved with a variance by the Town of Longboat Key since 32" of this seawall crosses onto our property (592 Ranger Lane, Lot 6, Block C, Country Club Shores).

Again, we have no objection to the seawall construction that has been completed on your property. We also understood that the seawall construction would extend onto our property by 32" and be built to code. As you seek a variance for the seawall construction that has been completed, we want to be sure that if/when approved, this variance covers the entirety of the wall which spans both of our properties (Lot 7 & Lot 6, Block C, Country Club Shores).

As a property owner on Longboat Key, Karen and I want to be sure that any construction on our property is done to code, and therefore creating no future negative impact for our property.

We sincerely hope that you can get this accomplished so that your seawall construction can be completed.

Sincerely,

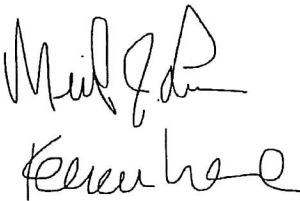
Handwritten signatures of Michael and Karen Leone. The signature for Michael is written in dark ink and is more stylized, while the signature for Karen is written in a lighter ink and is more cursive.

Michael and Karen Leone

Please note, here is historical information regarding why 32" of your seawall construction falls on our property.

*As we understand (we did not own the property at the time), several years ago when the contractor replaced the seawall at 592 Ranger Lane, Lot 6, Block C, Country Club Shores, they were forced to stop short of the property line so as not to jeopardize the integrity of your adjacent failing seawall.*











NOTE: MANTA RAY OPTION SHOWN.  
DEADMAN ANCHORS TO BE USED AS REQUIRED.

MANTA RAY ANCHORS

NOTE: EXISTING TIMBER PIN PILES  
TO REMAIN. PROPOSED WALL TO  
BE INSTALLED DIRECTLY IN FRONT  
OF PIN PILES.

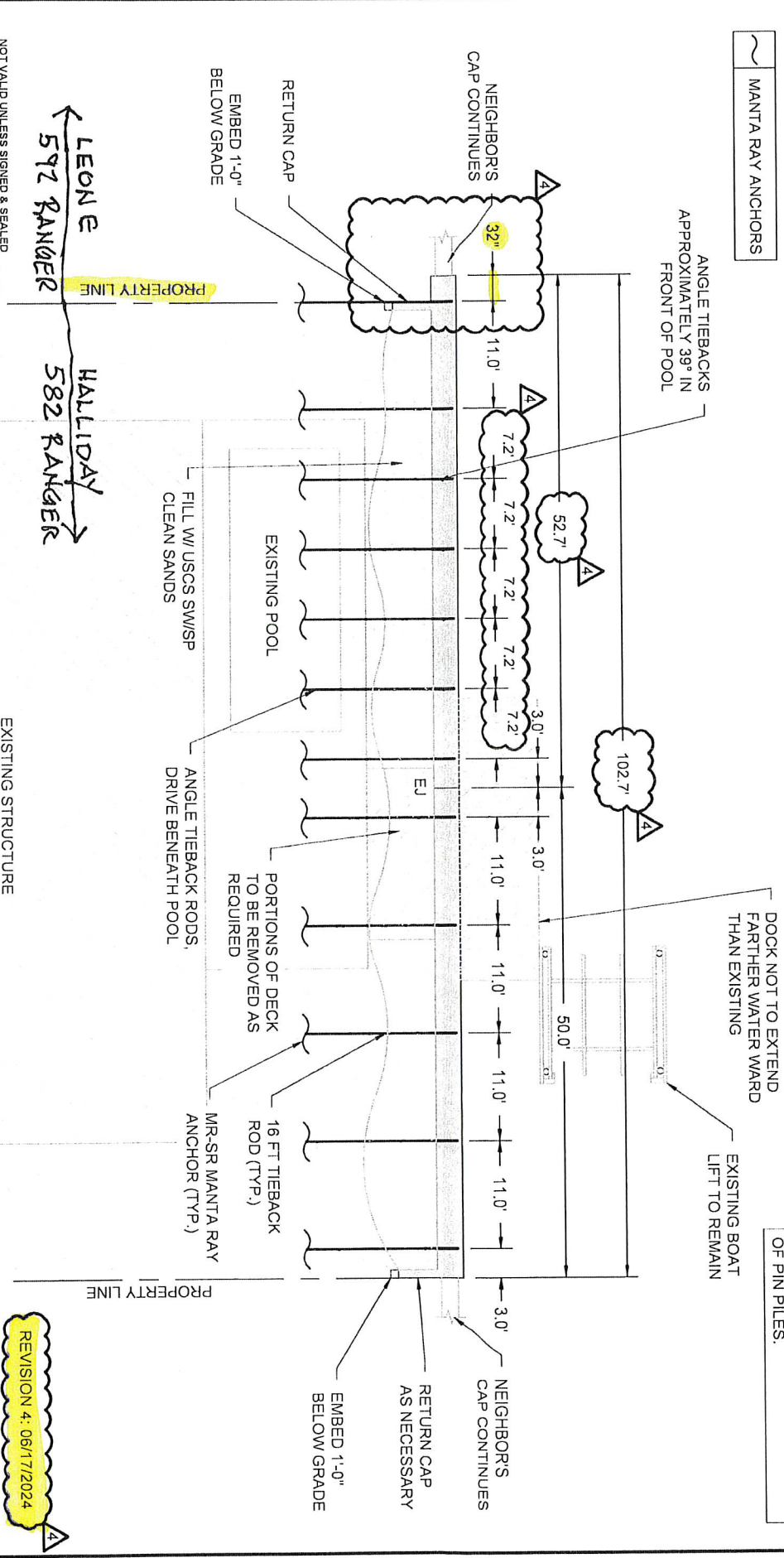

NOT VALID UNLESS SIGNED & SEALED

Professional Engineer Seal for Joseph Thomas Foster, No. 79708, State of Florida.

Joseph Foster  
Digitally signed by Joseph Foster  
Date: 2024.06.17 15:08:37 -04'00'

FOSTER CONSULTING logo and name.

FOSTER CONSULTING  
FL PROFESSIONAL ENGINEER NO. 79708  
DE LIC. # 18618 · NJ LIC. # 24GE09181200 · TX LIC. # 133648  
FL CERTIFICATE OF AUTHORIZATION NO. 32050  
WWW.JFOSTERCONSULTING.COM  
P: (727) 821-1949  
P.O. BOX 7370, ST. PETERSBURG, FL 33734

582 RANGER LN  
LONGBOAT KEY, FLORIDA  
SEAWALL PLAN

DATE:	03/15/23	FILE:	23092	REV:	4
DRAWN BY:	SIP	SHEET:	01 OF 02		
CHECKED BY:	JTF				
SCALE:	AS NOTED				

REVISION 4: 06/17/2024

PLAN  
SCALE: 1" = 15'-0"

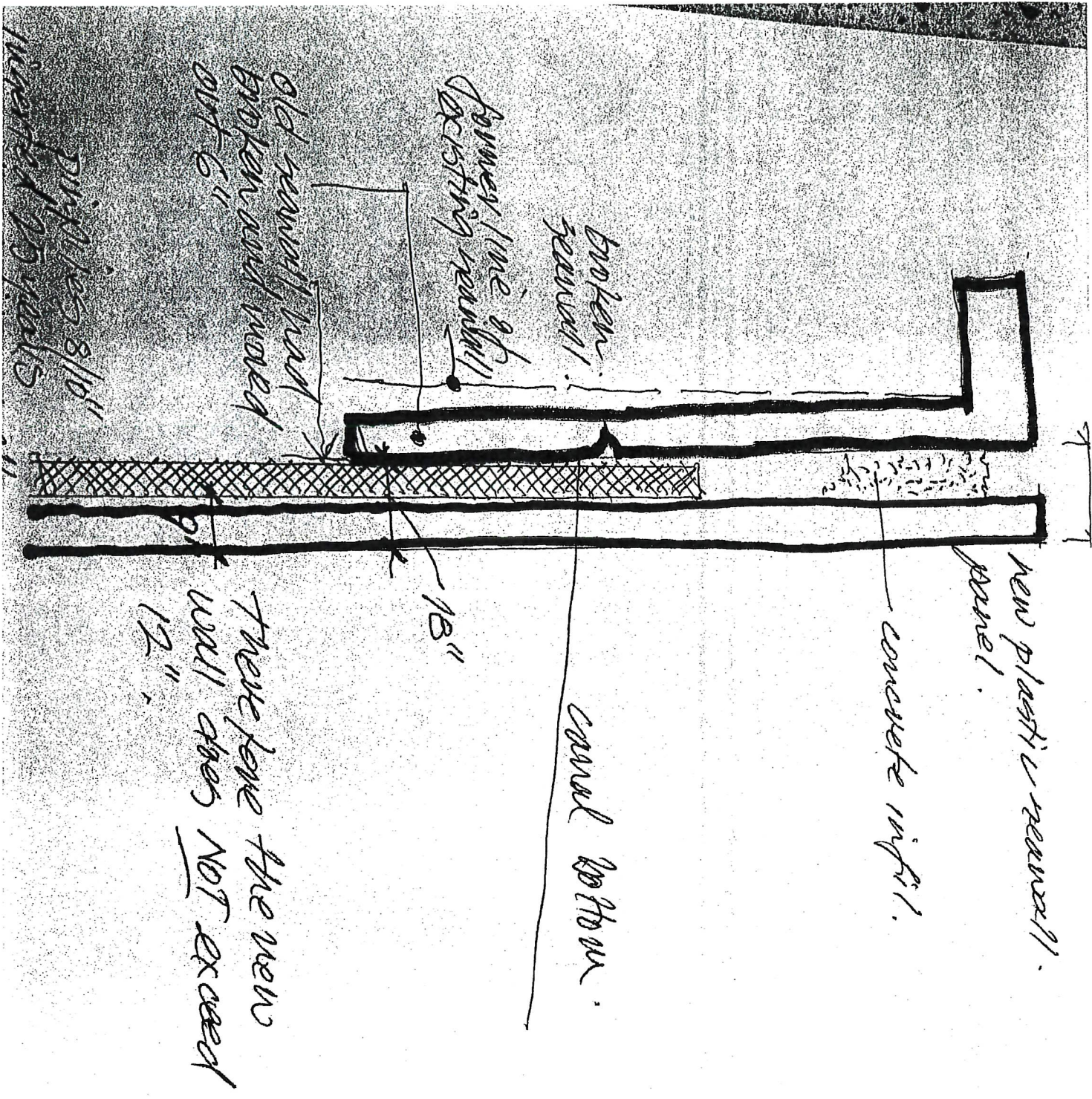

new plastic masonry panel.

concrete infill.

canal bottom.

18"

therefore the new wall does NOT exceed 12"

broken masonry!

lower line of existing masonry!

old masonry wall broken and moved out 6"

drill holes 8/10" inserted 15 quads

## Bruce franklin

---

**From:** Bobby Halliday <bobby@bobbyhalliday.co.uk>  
**Sent:** Monday, June 3, 2024 8:39 PM  
**To:** Bruce franklin  
**Subject:** FW: Your seawall  
**Attachments:** Halliday Plans.pdf

Bruce, this is quite interesting.....the plan is stamped approved by tate taylor.....shows the pin piles and the dimension of 12' from those pinpiles.  
bobby

**From:** Jay Johnson <jay@shorelineandfoundation.com>  
**Date:** Sunday, 12 May 2024 at 12:37  
**To:** Bobby Halliday <bobby@bobbyhalliday.co.uk>, Scott Liebel <scott@shorelineandfoundation.com>  
**Subject:** RE: Your seawall

Good afternoon, Bobby!

I struggled with whether to share this email with the entire chain below, or not. Obviously, this is my decision, and if you decide to share some of it with the community, that is entirely up to you. I'm not sure why everyone in your community is so persistent that the wall isn't constructed according to the plans submitted to the town of LBK, and approved by the town of LBK. What was brought to my attention when I was at your property late Friday afternoon getting measurements per Tate's, request was in reference to the 12" measurement "not to exceed".

It took me multiple times to finally get your neighbors on the east side of you to understand, and see that they were reading the plans wrong. They were insisting that the 12" measurement was in reference to your existing failed concrete wall. After multiple times of telling them they were looking at the plans wrong, and that the measurement in question was from the waterward face of the exiting timber pin piles, not the existing failed concrete seawall panel. Before I left, they fully understood that they had been looking at the plans wrong this entire time. I assume this is the same case with Lynn, and the Board members associated with your community.

The wall is being built per the plans approved by the town of LBK. Even though your wall is going to project out further than both your neighbors, it isn't going to affect the width of the navigable channel that is there now. Your lift is remaining in the same location, and your new dock when reinstalled will be 2' plus narrower than the existing dock you had.

My plan is to have guys on sight Monday morning to move the return on the east side over approximately 32". The new cap will still meet up with your neighbors. I explained this to them Friday afternoon, and they were good with that plan. I assured them that we would fill the hole back in, and supply whatever sod is needed. There are still some loose ends that need to be tightened up Monday, and part of Tuesday before the new wall will be ready for the new concrete cap. Are you okay with me proceeding forward with my plan while we continue working with Tate?

Regards,

## Attachment 'C'





# BENTLEY GOODRICH KISON

A COMMERCIAL LITIGATION LAW FIRM

MORGAN R. BENTLEY  
*Managing Shareholder  
Board Certified Business Litigation*

BRIAN D. GOODRICH  
*Shareholder*

AMANDA R. KISON  
*Shareholder  
Board Certified Business Litigation*

CAROLEEN B. BREJ

CORINNA S. COSER

KATLYN N. CRAIG

ASHLEY E. GAILLARD

KAYLIN M. HUMERICKHOUSE

MADELINE A. SALAMONE

ANDREW VAN NESS

DAVID A. WALLACE  
*Board Certified Appellate Law  
and Fla. Certified Mediator*

November 20, 2024

VIA Email: [Parsons@longboatkey.org](mailto:Parsons@longboatkey.org)

Allen Parsons, Director  
Planning, Zoning, and Building Department  
Town of Longboat Key  
501 Bay Isles Road  
Longboat Key, Florida 34228

Re: Appeal of Denial of Shoreline Construction Departure Request  
582 Ranger Lane & 592 Ranger Lane

Dear Mr. Parsons,

This Firm represents Robert Halliday (“Halliday”), owner of 582 Ranger Lane, Longboat Key, Florida (the “Property”), Michael Leone (“Leone”), owner of 592 Ranger Lane, Longboat Key, Florida, and Florida Shoreline and Foundation (the “Contractor”) (collectively referred to as the “Applicants”) relating to the August 14, 2024, Denial of the request for Departure from the Zoning Code. The Applicants submitted their Amended Appeal of an Administrative Official on September 19, 2024 but write here to provide additional information. The Public Hearing on the Applicants’ Appeal is set for December 2, 2024 before the Town of Longboat Key Town Commission.

In 2023, Mr. Halliday’s seawall was in desperate need of repair. The seawall was originally constructed at the time the Property was built in 1968. Since that time, the seawall has needed reinforcement. Specifically, the Property, as well as numerous other properties in the Country Club Shores community and throughout Longboat Key, experienced rotation of the panels due to there not being enough panel embedment into the canal. In response, pin piles were installed in front of the original seawalls throughout Longboat Key. It is estimated that the pin piles on Mr. Halliday’s property were installed before 1999 and they have since become a part of the seawall itself.

Mr. Halliday sought to replace the seawall on the Property in early 2023 when it became clear that the seawall was failing. As you know, this project was proceeding under a valid and proper building permit for 582 Ranger Lane issued by the Town. A copy of permit No. PB23-0253 is enclosed hereto for your convenience. At the time the permit was acquired, it was Mr. Halliday

and the Contractor's intention to remove the later installed pin piles and construct the new seawall directly in front of the original seawall. The seawall construction extended 32 inches onto the Leone property, at Leone's request, in order to close the gap between Leone's cap and seawall and Halliday's cap and seawall, which is a common practice.

During the course of construction, however, it was discovered that the structural integrity of the existing seawall was not as anticipated, specifically, the existing seawall panels were in a much more defective condition than expected. Given this discovery, the Applicants sought the opinion of Foster Consulting, an engineering firm specializing in marine construction. After inspection, the engineer determined that the pin piles could not be removed because they had become a structural part of the wall without which, the seawall would collapse. A copy of the report from Foster Consulting is enclosed hereto for your convenience.

According to the engineering report, the permitted plans required amendment to preserve the integrity of the upland area including the pool and pool deck located just ten feet away from the seawall and the neighboring properties. The solution was to keep the pin piles in place and incorporate them into revised plans. With the assistance of the structural engineer, the Applicants revised the plans and returned to the Town for approval. The Town approved the revised plans, and the Applicants resumed work on the project.

There seems to be some sort of misunderstanding as to the revised plans and the intentions of the Applicants during this process. The initial plans were created and submitted with the intention of removing the pin piles. Removal of the pin piles would have allowed the Applicants to stay within the permitted 12-inch seaward projection. At the time of initial permitting, the Applicants did not know that the pin piles had become a structural element of the seawall. When it became clear that removal of the pin piles was no longer possible, the Applicants sought the services of an engineer to best ensure both compliance with the Code and the structural integrity of the Property. The engineer's solution was to keep the pin piles in place and build the new seawall directly waterward of the existing timber pin piles.

This necessary change was immediately brought to the attention of the Town. Foster Consulting submitted its opinion on the pin piles on February 2, 2024. Thereafter, the Applicants submitted revised plans to the Town. In response, on February 16, 2024, the Town requested revised drawings/plans showing the pin piles and the proposed "fix." The Contractor submitted amended plans on April 10, 2024, which included specific section drawings labeling the new wall, the existing timber pin piles to remain, and the existing wall to remain. These drawings clearly indicated that the new wall would not exceed 12-inches *from the existing timber pin piles*, which Foster Consulting determined to be a part of the existing seawall and unable to be removed. The amended plans were reviewed for code compliance and approved on April 12, 2024. They were then reviewed for zoning compliance and approved on April 19, 2024. A copy of the approved amended plan is enclosed hereto for your convenience.

The Applicants sought approval from the Town because a later discovered change in circumstance necessitated alteration of the original permitted plans. The change order clearly depicted that the new wall would not exceed 12-inches from the waterward face of the existing timber pin piles, not the existing failed concrete seawall panel. The Applicants would have no reason to seek approval

from the Town if the project was able to stay within the permitted 12-inch seaward projection. Nevertheless, a change was required, and the Applicants went through the proper channels to address that change with the Town. Any suggestion that the Applicants submitted misleading drawings is belied by the approved drawings themselves and is simply baseless.

Notwithstanding the above history, the denial of the Departure Request must be reversed for two reasons. First, the new seawall only extends 12-inches from the existing seawall and is therefore permitted under the Town Code. Second, even if the Town does not agree that the structurally integrated pin piles are part of the existing seawall, there is good cause to approve the departure request as it is necessary to preserve the integrity of the uplands, and the departure request meets the intent of the Code. These reasons are discussed in further detail below.

Town Code Sec. 151.03(B)(3)(a) permits a homeowner to repair or replace existing seawalls so long as construction, inclusive of a buttress and seawall cap, does not protrude more than 12 inches seaward of the existing seawall or seawall cap. As more fully explained above, after initially intending to remove the pin piles, the Applicants were informed that the pin piles had become a structural element of the existing seawall. After inspection, Foster Consulting determined that the existing seawall could not exist without the pin piles; they are structurally unremovable. As a result, the Applicants revised the plans to include the pin piles and adjusted the dimensions accordingly. The new seawall protrudes no more than 12 inches from the waterward face of the existing timber pin piles, not the failed concrete seawall panel. Therefore, Town Code Sec. 151.03(B)(3)(a) applies, and the new seawall construction must be approved.

In the alternative, if the Town does not agree and the Town's view is that the existing failed concrete seawall does not include the existing timber pin piles, the Applicants are before the Town seeking a departure from the code. Notwithstanding that the longstanding policy of the Town has been to minimize encroachment into canals in order to maintain their navigability over time, the code permits departures under Section Town Code Sec. 151.03(E).

The departure must be granted. The only safe way to construct the new seawall is to build it directly against the waterward face of the existing timber pin piles. According to the engineer who physically inspected the existing wall and the pin piles, removal is not possible without a complete failure of the wall, putting the upland structures at risk of damage and movement and allowing the upland sediment to displace into the water, decreasing water quality in the canal. As a result, Foster Consulting recommended installing new vinyl seawall panels waterward of the existing timber pin piles to prevent wall failure and preserve the upland.

The revised plan results in a departure request of 15.25 inches seaward to account for the structurally integrated pin piles. It must be noted that the Applicants both have docks and boat lifts that extend more than twenty feet further than the existing seawall into the canal so any additional seaward protrusion with the new seawall would not decrease the navigable water of the canal. In fact, the plans indicate that the width of the existing dock on Mr. Halliday's property would be narrowed.

In the Wood Dock & Seawall professional opinion provided with the Denial, the Town suggests that the Applicants can "remove/relocate the brace pins as [they] install the sheet pile adjacent to

the face of the existing sea wall panels,” and “install the bolts, jacks, and tie back as [they] proceed to install the sheet pile.” While the Applicants agree that removal of the pin piles is often a solution, the method described by Wood Dock & Seawall cannot be accomplished with this specific seawall without substantial damage to the upland areas. Installing bolts, jacks, and tie backs would not solve the problem of this failing old concrete seawall. The Wood Dock & Seawall opinion also suggests that the Applicants “can install additional bracing on the water side of the sea wall jacks,” and “excavate behind the wall to relieve pressure if there is room.” Installing additional bracing is not a viable option here due to the condition of the failing old concrete seawall. If new or additional pin pile braces or jacks were to be installed, the water jetting would cause weakening of the surrounding soils and the nearby concrete panels to move. If the additional or new piles were to be driven or pounded in, the vibration of the driving would have a similar effect as the jetting. Further, excavating behind the wall is not an option due to the pool.

These alternative construction methods fully depend on the condition of the existing seawall, a concession Wood Dock & Seawall includes in its professional opinion. Wood Dock & Seawall did not personally inspect the seawall at issue. Foster Consulting considered the possibility of incorporating the pin piles into the new seawall and removing the pin piles one at a time as the new seawall was being constructed. After inspecting the pin piles, that option was ruled out. Due to inconsistent spacing of the pin piles, incorporating the pin piles into the corrugations of the new seawall is impossible. On occasion the pin pile may fall within the corrugation, but this would not be the case for the entire length of the seawall. When the pin pile conflicts with the wall and doesn't fall within the corrugation, it would need to be removed, which is not a possibility here. The pin piles cannot be removed.

The Denial mentions a few other issues which are briefly discussed below.

First, this is not an after-the-fact departure request. Permits and revised plans were reviewed and approved by the Town. When the Town requested clarification, the Applicants provided same. When no further concerns were raised, the Applicants continued with the approved plans. It was not until the Town issued a Stop Work Order on May 13, 2024, that the Applicants were on notice that the approved plans required additional consideration. Because of this, the Applicants first sought to submit a variance but ultimately submitted a departure request on June 28, 2024. The plans have not changed since they were approved on April 12, 2024, and April 19, 2024, the Applicants have only clarified.

Second, dimensioned drawings were not requested. Foster Consulting submitted its opinion on the pin piles on February 2, 2024. The Applicants submitted revised plans to the Town. Thereafter, the Town requested revised drawings/plans that showed a “detailed cross section of existing and proposed design of seawall showing location of pin piles and proposed improvement.” The drawings submitted in response to the Town's concerns clearly depicted the intent of the project to construct the new seawall, showing the location of the pin piles and the proposed “fix.” These drawings showed that the new seawall would not extend more than 12 inches from the waterward face of the existing timber pin piles. No further concerns were raised by the Town until the Stop Work Order was issued. When the issue of dimensions was raised, the Applicants promptly complied and submitted drawings noting the dimensions of the approved drawings. The drawings

clearly show the new seawall extending 12 inches from the waterward face of the existing timber pin piles, not incorporating the pin piles within the new seawall.

Third, the Applicant was not and is not attempting to avoid permitting. Rather, the Applicants obtained a permit prior to any construction and have quickly communicated the issues and necessary changes to the Town. In addition, the Applicants have submitted all information requested of them throughout the process.

The denial seems to suggest that the Applicants are attempting to encroach into the canal by pulling a fast one. This could not be more from the truth. The Applicant encountered unexpected obstacles during the construction process and kept the Town informed throughout the entire process. At this point, construction of the new seawall is ninety percent (90%) complete. The change plans submitted and approved in April 2024 presented the option with the least amount of intrusion possible while maintaining the integrity of the upland. The Applicants ask that you reverse the decision of the Zoning and Building Department and allow the Applicants to complete construction of the seawall as this plan meets the intent of the Code and ensures the protection of the upland area on the Property and neighboring properties.

I hope that these comments and concerns help guide your review of the Applicants' Appeal of the Denial of the Departure Request. Please do not hesitate to contact me with any questions.

Sincerely,



Morgan Bentley  
For the Firm

Encl.

cc: Robert Halliday  
Michael Leone  
Florida Shoreline and Foundation  
Maggie Mooney, Town Attorney  
Town Clerk



# PERMIT

PERMIT NUMBER:

**PB23-0253**

PERMIT TYPE:

**BUILDING -  
DOCK/SEAWA  
LL/LIFT**

**ISSUED: 04/20/2023**

**ADDRESS: 582 RANGER LN**

USE: RESIDENTIAL

**WORK DESCRIPTION: INSTALL NEW SEAWALL**

OWNER: HALLIDAY ROBERT

CONTRACTOR: Florida Shoreline & Foundation Experts LLC

CONTRACTOR PHONE: (941) 927 1410

LICENSE: CBC1260841

STIPULATIONS: Seawall construction height shall not exceed a maximum height of 4.5-foot elevation (NAVD 1988) inclusive of the seawall cap.

Construction, inclusive of a buttress and seawall cap, shall not protrude more than 12 inches seaward of the existing seawall or seawall cap. Notwithstanding the foregoing, if there are two existing seawalls abutting the subject replacement seawall of differing seaward projections, then the subject replacement seawall shall be further limited to a seaward projection distance of no more than either equal to the immediately abutting seawall with the least projection or a total seaward projection of 12 inches, whichever is less.

*Note: Contractors/owners please contact your community association prior to start of any work.*

IT IS THE RESPONSIBILITY OF PERMIT HOLDERS OF EACH PHASE OF WORK TO PROCURE INSPECTIONS AS REQUESTED AND TO VERIFY APPROVALS PRIOR TO PROCEEDING TO NEXT PHASE.

## INSPECTIONS:

Building - Dock/Seawall/Lift Inspections (PERMIT REQUIRED)				
Permit Number:				
TYPE	STATUS	INSPECTOR	DATE	COMMENTS
Tieback Anchor/Deadman				
NPDES				
Cap Steel				
Final Building				
Other				

NOTICE (Fla. Statute 553.79(10)): In addition to the requirements of this permit, there may be additional restrictions applicable to this property that may be found in the public records of the county, and there may be additional permits required from this or other governmental entities such as water management districts, state or federal agencies.

PERMITS FOR DEMOLITIONS OR RENOVATIONS OF AN EXISTING STRUCTURE: This is notification of the owners or owner's representative's responsibility to comply with provisions of s. 469.003 Florida Statutes printed below, regarding Asbestos Abatement and to notify the Department of Environmental Protection of your intentions to remove asbestos, when applicable, in accordance with the state and federal law.

F.S. 469, Asbestos Abatement. 469.003 License Required

- (1) No person may conduct an asbestos survey, develop an operation and maintenance plan, or monitor and evaluate asbestos abatement unless trained and licensed as an asbestos consultant as required by this chapter.
- (2) No person may prepare asbestos abatement specifications unless trained and licensed as an asbestos consultant as required by this chapter.
- (3) No person may contact the department under this chapter as an asbestos contractor, except as otherwise provided in this chapter.

~~WARNING TO OWNER: YOUR FAILURE TO RECORD A NOTICE OF COMMENCEMENT MAY RESULT IN YOUR PAYING TWICE FOR IMPROVEMENTS TO YOUR PROPERTY. IF YOU INTEND TO OBTAIN FINANCING, CONSULT WITH YOUR LENDER OR AN ATTORNEY BEFORE RECORDING YOUR NOTICE OF COMMENCEMENT.~~

**130.02(C) Unreasonable Sound Prohibited**

(2)(f) Construction and demolition. Engaging in construction or demolition on Sunday, on any holiday, or between the hours of 5:00 p.m. and 8:00 a.m. Monday through Saturday except for emergency work by a public service utility or by other permit approved by the town. This sub section shall not apply to the use of domestic power tools as specified in subsection (i) of this section.

**PARKING INFORMATION**

*For properties along Gulf of Mexico Drive:*

Parking along the entire length of Gulf of Mexico Drive is prohibited. Vehicles that are parked along either side of Gulf of Mexico Drive are subject to a \$75 parking citation.

*For properties in the Village:*

Service Vehicles (a "vehicle with a business sign or logo owned and operated by a person, firm or corporation actively engaged in a service or business activity at the home of Resident within the Resident-Only Parking Permit area") can park on Village streets that allow Resident-Only Parking. Service vehicles are encouraged to use Resident-Only spaces rather than parking in the limited publicly available parking spaces.

**PERMIT MUST BE POSTED IN A CONSPICUOUS LOCATION VIEWABLE FROM ROAD.  
INSPECTION REQUESTS REQUIRED AT LEAST 24 HOURS IN ADVANCE.  
REQUESTS: 941-316-1966**

February 2<sup>nd</sup>, 2024

Florida Shoreline & Foundation  
4561 Clark Rd.  
Sarasota, FL 34233

Re: Seawall replacement at 582 Ranger Ln. Longboat Key, FL 34228

To Whom It May Concern,

The seawall at the subject property is in severe condition and is in need of replacement. The concrete panels have buckled near the mudline and are kicking out waterward. Timber pin piles were installed at some time in the past in an effort to stabilize the wall. Removal of the pin piles may allow the wall to fail completely, allowing the upland sediment to displace into the water, decreasing water quality in the canal. Furthermore, a failure of the wall, or removal of the failed concrete slabs, would put the upland structures, including the pool, at severe risk of damage and movement. For these reasons, it is recommended to install the new vinyl seawall panels waterward of the timber pin piles to prevent a wall failure and preserve the upland.

If there are any questions, please call. Thank you for the opportunity to be of service.

Sincerely,

Foster Consulting

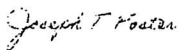

Joseph T. Foster, P.E.  
FL Lic No. 79708  
NJ Lic No. 24GE05181200  
DE Lic No. 18618

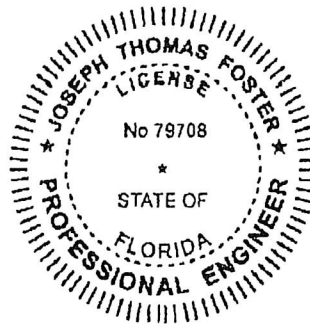

Joseph  
Foster

Digitally signed  
by Joseph  
Foster  
Date:  
2024.02.02  
09:39:05 -05'00'



NOTE: EXISTING TIMBER PIN PILES TO REMAIN. PROPOSED WALL TO BE INSTALLED DIRECTLY IN FRONT OF PIN PILES.



4/19/2024, 7:05:57 PM  
PB23-0253  
Tate Taylor

NOTE: MANTA RAY OPTION SHOWN. DEADMAN ANCHORS TO BE USED AS REQUIRED.

MANTA RAY ANCHORS



4/12/2024, 6:34:00 PM  
PB23-0253  
Jonathan ~~Ray~~ CAP AS NECESSARY

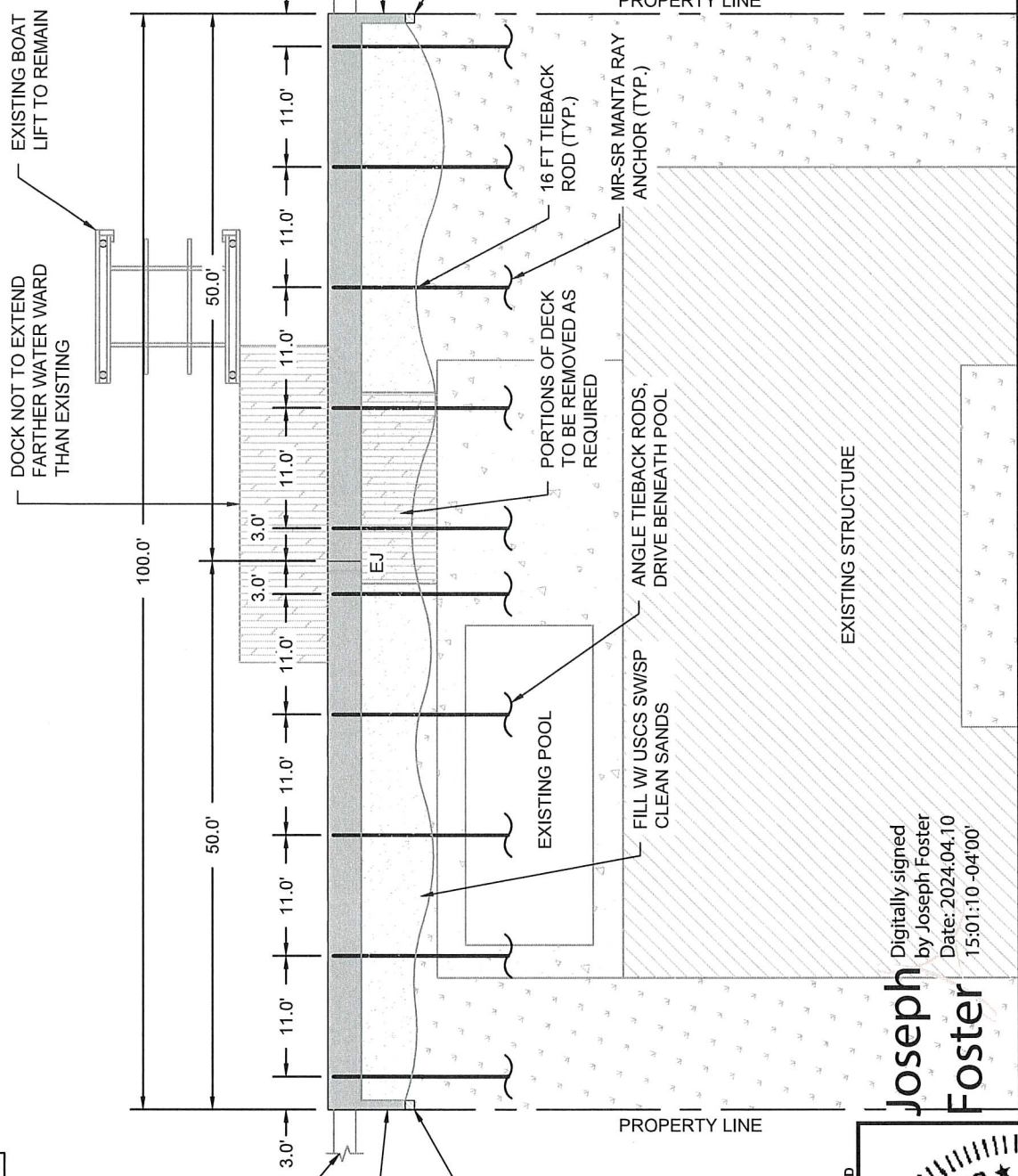

PLAN  
SCALE: 1" = 15'-0"



Joseph Foster  
Digitally signed  
by Joseph Foster  
Date: 2024.04.10  
15:01:10 -04'00'

DATE:	03/15/23	FILE:	23092
DRAWN BY:	SIP	SHEET:	01 OF 02
CHECKED BY:	JTF	SCALE:	AS NOTED
			<b>01</b>

582 RANGER LN  
LONGBOAT KEY, FLORIDA

**SEAWALL PLAN**

**FOSTER CONSULTING**  
FL PROFESSIONAL ENGINEER NO. 79708  
DE LIC. # 18618 - NJ LIC. # 24GE05181200 - TX LIC. # 133648  
FL CERTIFICATE OF AUTHORIZATION NO. 32050  
[WWW.JFOSTERCONSULTING.COM](http://WWW.JFOSTERCONSULTING.COM)  
P: (727) 821-1949  
P.O. BOX 7370, ST. PETERSBURG, FL 33734

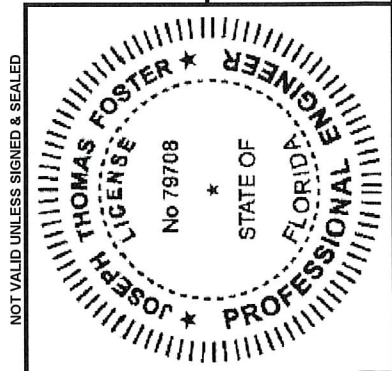

NOT VALID UNLESS SIGNED & SEALED

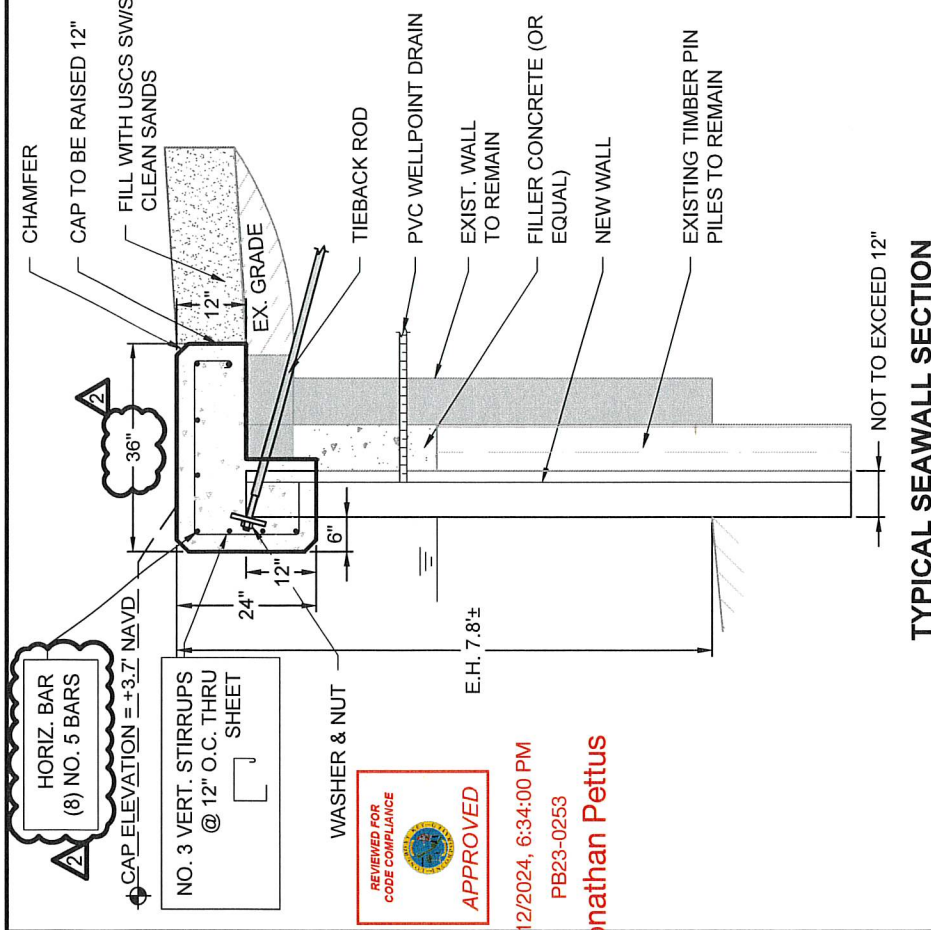
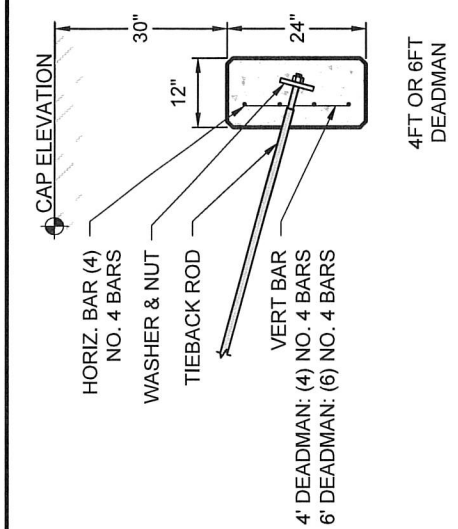
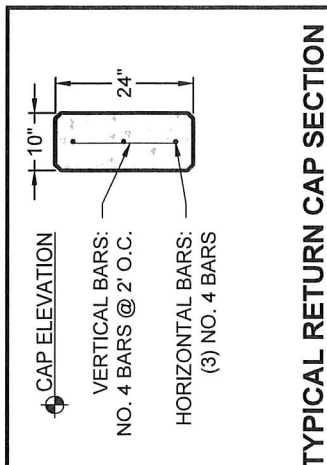

REVIEWED FOR CODE COMPLIANCE

APPROVED

4/12/2024, 6:34:00 PM

PB23-0253

Jonathan Pettus

REVISION 2: 04/10/2024

Joseph Foster

Digitally signed by Joseph Foster

Date: 2024.04.10 15:01:25 -04'00'

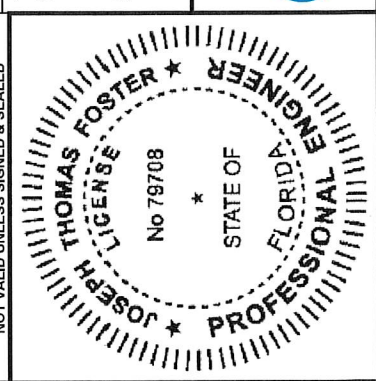

**CONSTRUCTION NOTES:**

1. CONCRETE - 5000 PSI (CAP) & 3500 PSI (FILLER) AT 28 DAYS
2. SHEETS - 14 FT LONG VINYL SHEET PILE (CL - 9900, ESP 6.5, SG - 550, TW - 70, TRULINE\*, OR VANGUARD STD). \*TRULINE CONTACT E.O.R FOR ADDITIONAL SPECS.
3. TIEBACK RODS - 1" x 16 FT PVC ENCASED TIEBACK ROD WITH (2) HDG 6" x 6" x 1/2" PLATE WASHERS & NUTS AT EACH END WITH CONCRETE DEADMAN OR 1" x 16 FT HDG TIEBACK ROD W/ (1) HDG PLATE WASHER & NUT CONNECTED TO MR-SR MANTA RAY ANCHORS TENSIONED TO 13000#.
4. REBAR - GRADE 60. PLAIN.
5. DRAINS - 1.25" DIA. X 4FT LONG SLIT TYPE PVC WELL POINT DRAINS THROUGH BOTH WALLS AT 6' CENTERS 6" ABOVE THE BARNACLE LINE.
6. MEETS FBC 2020 - 7TH EDITION

<b>FOSTER CONSULTING</b>		582 RANGER LN LONGBOAT KEY, FLORIDA	
FL PROFESSIONAL ENGINEER NO. 79708 DE LIC. # 18618 - NJ LIC. # 24GE05181200 - TX LIC. # 133648 FL CERTIFICATE OF AUTHORIZATION NO. 32050 WWW.JFOSTERCONSULTING.COM P: (727) 821-1949 P.O. BOX 7370, ST. PETERSBURG, FL 33734		SECTION	
DATE: 03/15/23	FILE: 23092	REVISION: 02 OF 02	02
DRAWN BY: SIP	CHECKED BY: JTF	SCALE: AS NOTED	

Attachment 'D'



# TOWN OF LONGBOAT KEY

Planning, Zoning & Building  
501 Bay Isles Road  
Longboat Key, FL 34228  
(941) 316-1966  
www.longboatkey.org

*Incorporated November 14, 1955*

August 14, 2024

Mr. Bruce Franklin  
Land Resource Strategies, LLC  
1555 Fruitville Road  
Sarasota, FL 34236

Via: Email & U.S. Mail  
bfranklin@srqplanning.com

RE: Shoreline Construction Departure Request  
592 Ranger Lane

Dear Mr. Franklin,

Thank you for your Shoreline Construction Departure request (per Town Code Sec. 151.03(E)<sup>1</sup>) of June 28, 2024, for two adjacent properties located at 582 (Parcel ID No. 0010020008) and 592 (Parcel ID No. 0009160031) Ranger Lane.

The Town Manager has directed the Town's Planning & Zoning Department to respond to your Departure requests. Accordingly, the Town Planning & Zoning Department's analyzed the Departure requested for each of the properties and prepared separate responses for each property. This response is for the property at 592 Ranger Lane, where an after-the-fact permit for construction of 32 inches of seawall was received by the Town on June 30, 2024.

The requested Departure is being sought for a new corrugated seawall that has been partially constructed, in front of (waterward) an existing concrete seawall with a total width of 27.25 inches. This width is 15.25 inches greater than allowed by Town Code Sec. 151.03(B)(3)(a), which provides for the "...replacement of existing seawalls within an existing subdivision or developed area...as follows:"

***"Construction, inclusive of a buttress and seawall cap, shall not protrude more than 12 inches seaward of the existing seawall or seawall cap. Notwithstanding the foregoing, if there are two existing seawalls abutting the subject replacement seawall of differing seaward projections, then the subject replacement seawall shall be further limited to a seaward projection distance of no more than either equal to the immediately abutting seawall with the least projection or a total seaward projection of 12 inches, whichever is less."***

Sec. 151.03(E): "Any request for a departure from the requirements of this Code, or any dispute as to structural integrity of any structure proposed under this Code, shall be resolved by the town manager or designee. Any expertise necessary to assist the town manager or designee in making that decision shall be at the applicant's expense. In making the determination as to whether to grant a departure, the town manager or designee must determine that the proposed design meets the intent of this chapter."

As noted in your correspondence, the Departure request is not being sought prior to construction, but at a point where, "[t]he project sits at 90% complete with only the seawall cap to be poured and landscaping to be installed." Therefore, before providing the staff assessment and response to this after-the-fact Shoreline Construction Departure request, a review of the building permit application for the seawall at the neighboring property (582 Ranger) and the after the fact application for the subject property is provided below.

## Seawall Permit Background/Timeline

1. March 23, 2023. Florida Shoreline (Contractor) submits a building permit application (Town Building Permit #PB23-0253) to install a new corrugated seawall waterward of an existing concrete seawall at 582 Ranger Lane, which immediately adjacent to and next door to 592 Ranger Lane. (Note: Building permit application did not depict or include seawall construction occurring at 592 Ranger Lane.)

Description: The permit application for the 582 Ranger Lane property and the plans show the new corrugated seawall, cap and concrete filler or equal to not to be more than 12" waterward of the existing seawall and seawall cap. An annotated excerpt from the 582 Ranger Lane Section View application to the Town is shown below.

April 19, 2023. Building permit issued for 582 Ranger Lane only.

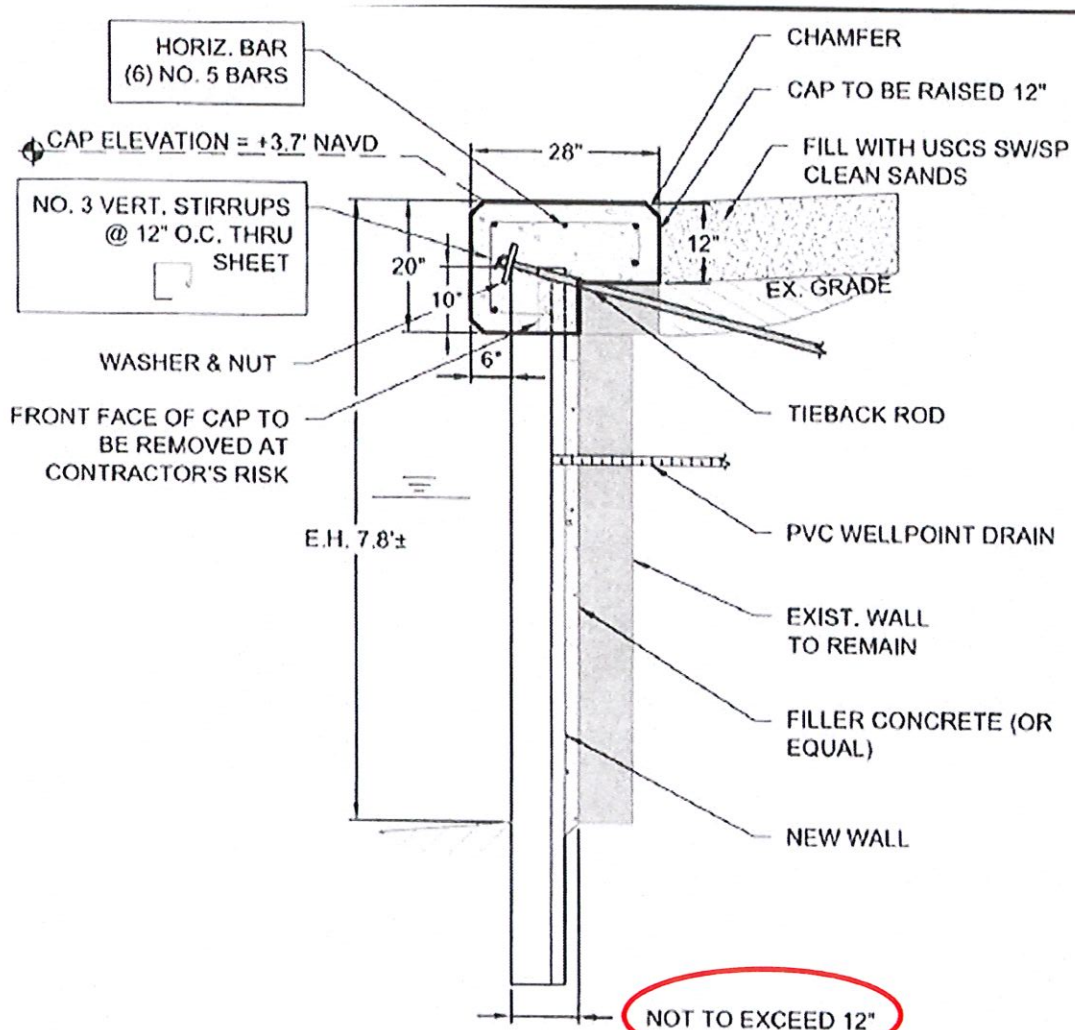

losep

Digitally  
signed by  
Joseph Foster

**TYPICAL SEAWALL SECTION**

2. February 12, 2024. Contractor (Florida Shoreline) submitted a permit Change Order request to the approved permit at 582 Ranger Lane.

Description: The Change Order request for 582 Ranger Lane consisted of a letter dated, February 2, 2024, from Foster Consulting (copy provided below), describing the condition of the existing seawall and stated that the wall was being supported by timber pin piles. This change order did not provide any plans or drawings showing any change to the construction. The change order was disapproved by the Building and Zoning reviewers on February 16, 2024. Reviewers requested detailed plans of the existing and proposed design of the new corrugated seawall and the location of the pin piles including more detailed information on the plans regarding the timber pin piles and proposed (Note: Building permit application did not depict or include seawall construction occurring at 592 Ranger Lane).

February 2<sup>nd</sup>, 2024

Florida Shoreline & Foundation  
4561 Clark Rd.  
Sarasota, FL 34233

Re: Seawall replacement at 582 Ranger Ln. Longboat Key, FL 34228

To Whom It May Concern,

The seawall at the subject property is in severe condition and is in need of replacement. The concrete panels have buckled near the mudline and are kicking out waterward. Timber pin piles were installed at some time in the past in an effort to stabilize the wall. Removal of the pin piles may allow the wall to fail completely, allowing the upland sediment to displace into the water, decreasing water quality in the canal. Furthermore, a failure of the wall, or removal of the failed concrete slabs, would put the upland structures, including the pool, at severe risk of damage and movement. For these reasons, it is recommended to install the new vinyl seawall panels waterward of the timber pin piles to prevent a wall failure and preserve the upland.

If there are any questions, please call. Thank you for the opportunity to be of service.

Sincerely,

Foster Consulting

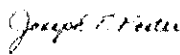

Joseph T. Foster, P.E.  
FL Lic No. 79708  
NJ Lic No. 24GE05181200  
DE Lic No. 18618

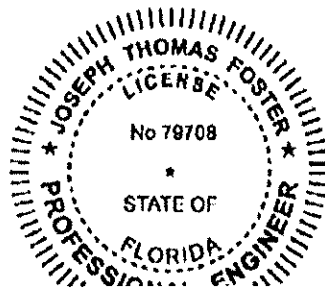

Digitally signed  
by Joseph  
Foster  
Date:  
2024.02.02  
09:39:05 -05'00'

**Joseph  
Foster**

3. March 1, 2024. Revised Change Order plans submitted with plans for 582 Ranger Lane. Section view detail (provided below) did not indicate the dimensions the timber pin piles and that the new corrugated seawall could not be constructed around or otherwise incorporate the existing timber pin piles within the maximum Town Code required 12 inches as required by Town Code Section 151.03. Staff approved plans on March 6, 2024, with a Condition of Approval, on the Permit Card for 582 Ranger Lane, that the new seawall not protrude more than 12 inches waterward of the existing seawall. The Condition of Approval allowed for

construction of the new corrugated seawall to be accomplished by working around and incorporating existing timber pin piles. An annotated excerpt from the Section View revised plans for 582 Ranger Lane indicating a “not to exceed” 12-inch seaward extension of the new seawall submitted to the Town is shown below.

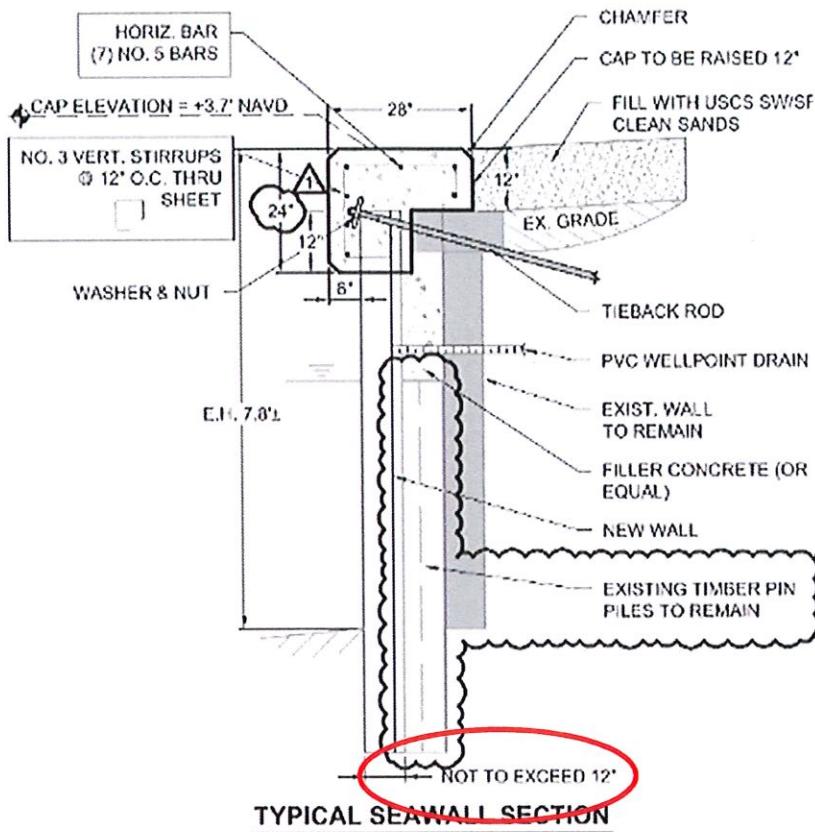

4. April 11, 2024. Revised Change Order plans submitted for 582 Ranger Lane. Change Order requested landward-oriented modification to the seawall cap *only*, by adding 8 inches to the overall width of the seawall cap increasing the cap to 36" in width (Section view detail provided below). (Note: Building permit application did not depict nor include seawall construction occurring at 592 Ranger Lane.).

April 19, 2024. Revised Change Order plans for 582 Ranger Lane approved for landward modification to seawall cap.





7. May 9, 2024. The Town's Zoning Staff received an email from Scott Liebel (Contractor and owner of Florida Shoreline). The email (copied below) relates to the submittal of a requested survey to address the reported property line issue with the 582 Ranger Lane seawall construction extending onto the adjacent property at 592 Ranger Lane. The email indicates that neither the contractor nor the 582 Ranger Lane property owner could locate a survey for 582 Ranger Lane and that the seawall construction did not extend into the adjacent property at 592 Ranger Lane.

Email from Scott Liebel, May 9, 2024

Good afternoon Tate. Thanks for the call earlier. My office should be uploading the sketch and summary of the project shortly (if they haven't already).

You also asked for a survey of the property. We don't have one, and Bobby Halliday isn't finding one yet either. But, we did speak with Mike Leone, and he shared his, and is working with us to ensure the return wall is constructed properly and to his satisfaction. Hope this is good with you. If I need to upload this, or do anything else regarding the property line issue, please do not hesitate to call.

Thanks,

**Scott Liebel**

8. May 10, 2024. Phone call between the Town Zoning staff and Scott Liebel (Contractor and owner of Florida Shoreline) indicating that staff had done a records search and did not find record(s) of prior permitting for the installation of timber pin piles at 582 Ranger Lane. Note: No records for timber pin piles were found for the 592 Ranger Lane property. An opportunity was provided for the Contractor to provide documentation that a prior building permit had been obtained to place the timber pin piles in front of the seawall. Scott Liebel stated that he also could not find record(s) of a permit being issued for the timber pin piles.
9. May 10, 2024. Supplemental plans submitted, with a letter, dated May 9, 2024, from Scott Liebel (Contractor and owner of Florida Shoreline), providing an additional AFTER-THE-FACT revised seawall cross section, and survey of the adjacent property at 592 Ranger Lane due to the fact that seawall construction extended approximately 32 inches onto the adjacent property at 592 Ranger Lane (provided below).



May 9, 2024

Mr Tate Taylor  
Town of Longboat Key

Re: 582 Ranger Lane, Permit #PB23-0253

Dear Mr. Taylor

As discussed, please accept this letter as a follow up to our discussion regarding the construction of the new seawall at 582 Ranger Lane, and an explanation of what existed before we began work and what the end result will be.

The seawall at 582 Ranger Lane is an original concrete seawall which was constructed approximately 60+ years ago. Some time after the initial construction, wood "pinpilings" were installed in front of the existing wall. These pinpiles were installed in front of seawalls which were experiencing rotation of the panels due to not enough panel embedment into the canal (a common problem in Country Club Shores). Many of these pin piles were installed before I started in the marine construction industry in 1999 so I estimate the pilings at 582 Ranger Lane were installed pre-1999. The pinpiles became an integral part of the seawalls. Without the pinpiles many seawalls in Country Club Shores, including this one, would have failed long ago. To prevent the need for pinpilings, new sheet panel seawalls are constructed with 40% or more of the panel length embedded into the canal bottom.

When we applied for the permit to build the new wall at 582 Ranger Lane the initial plan was to remove the pinpiles and install the new sheet panels immediately in front of the existing wall. Upon mobilization to the site and further inspection of the wall it was discovered just how bad of condition the wall was in. The concrete panels were cracked and broken. The only thing keeping the wall in place and vertical was the pinpiles. Removal of the pinpiles would most certainly result in immediate failure of the seawall, and due to the close proximity of the pool, the pool would suffer significant damage as well. Foster Consulting prepared a letter summarizing the issues, followed by engineered plans showing the pinpiles to remain and the new panels to be no more than 12" waterward of these piles.

The new seawall at 582 Ranger Lane will not have any negative affect to the neighbors nor to navigation, and I believe meets the plans submitted. Without the approval of the pinpiles staying in place, it would have resulted in significant and unnecessary damage to this property and most probably the adjoining properties as well. Attached is a sketch showing in more detail the dimensions of the wall in relation to the neighboring wall to the east.

I hope this helps clarify what is being built and why it is being built the way it is. If you have any questions please do not hesitate to call.

Respectfully submitted,

Scott Liebel  
Florida Shoreline and Foundation

Plan Section View Provided as Part of May 10, 2024 Submittal

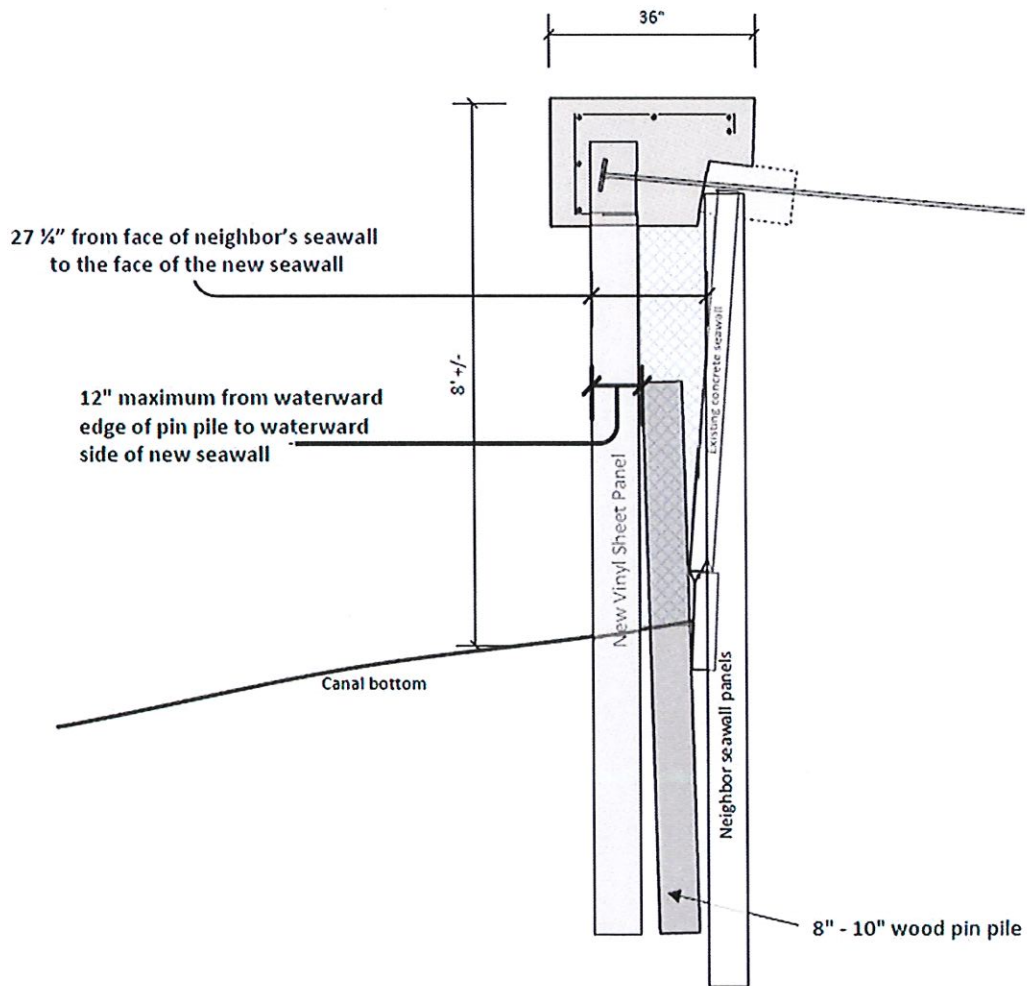



seawall cap to a maximum of six (6) inches. The intent of the code was to allow for the installation of a refacing seawall or replacement seawall with limited height and waterward projections.

Multiple requests for administrative Departures (per Sec. 151.03(E)) related to replacement seawalls constructed waterward (in front of) existing seawalls prompted an amendment to the replacement seawall construction requirements in 2018. Revisions to Sec. 151.03(B)(3)(a) were adopted to allow a twelve (12) inch projection for replacement seawalls. This was based on a number of granted Departures (typically to a maximum dimension of 12 inches) that reflected that most modern seawall panels were approximately eight (8) inches deep, which exceeded the prior maximum six-inch projection.

Other than this Departure request, no other Departure requests have been received by the Town since the Zoning Code was amended in 2018 to allow for up to a foot of seaward projection (as measure from the existing seawall) for the construction of replacement seawalls. The Town's longstanding policy has been to minimize encroachment into canals in order to maintain their navigability over time.

Section 151.03(E) authorizes the Town Manager or designee to grant Departures to this section when it can be determined that a proposed design meets the intent of Chapter 151.

#### **Summary of Applicants' Departure Request Submitted on Behalf of Properties (582 and 592 Ranger Lane)**

The June 28, 2024, Departure request is to authorize an after-the-fact replacement seawall width of an additional 15.25 inches for both properties (582 and 592 Ranger Lane). The total width of newly waterward projecting seawall is 27.25 inches. The maximum allowable waterward projection is 12 inches ( $27.25" - 12" = 15.25"$ ).

According to the Departure request, the existing seawall was constructed approximately 60 years ago when Country Club Shores was developed. Staff could not find the original seawall construction building permit. However, this approximate age is likely accurate.

The Departure request also indicates in approximately 1999, wooden 'pin pilings' were installed to stabilize the failing wall panels without a permit which was a common practice all over Country Club Shores, according to the Contractor. As noted earlier, the Contractor, property owner, and staff could not find record of a building permit associated with the timber pin piling installation.

As described in the Departure request, the Contractor for the new seawall at 582 Ranger Lane was aware of the timber pin pilings and assumed they would remove them once construction began, as they have been able to do in other instances. Upon construction mobilization, the Contractor indicated that it was found that the existing seawall panels were in a defective condition and were evaluated by an engineer. The engineer provided an opinion to the Contractor that the pin pilings should not be removed as they were integral to the existing seawall system.

Note: The engineer's opinion did not specifically address the existing seawall located at the 592 Ranger Lane property, nor was the permitting history or structural components (i.e. the existence of timber pin piles) of the pre-existing seawall evaluated. Accordingly, it is unclear whether the same concerns associated with the 582 Ranger Lane seawall failing, if the pin pilings were removed, are applicable to the 592 Ranger Lane property. For example, unlike the 582 Ranger

Lane property, the 592 Ranger Lane does not have a similarly situated swimming pool proximate to the canal that would be at risk of failure.

### **Staff Analysis**

Staff's initial approval (April 19, 2023) of the corrugated seawall for 582 Ranger Lane was based, in relevant part, on application materials, including plan and section views, that depicted a replacement seawall extending no more than 12 inches waterward of the property's existing seawall for that particular property. This approval did not include construction being depicted at the 592 Ranger Lane property.

Staff subsequently approved a Change Order request for 582 Ranger Lane (March 6, 2024) based, in relevant part, on application materials, including a Typical Seawall Section view detail, that continue to indicate compliance with the not to exceed 12 inch waterward Code requirement. The applicant (for 582 Ranger Lane) misrepresented the dimensions of the timber pin piles and filler concrete or equal on those submittals. The application materials for 582 Ranger Lane also misrepresented how the new corrugated seawall would be constructed, incorporating the existing timber pin piles within the maximum Town Code required 12 inch waterward projection. Staff experience in processing seawall replacement permits has shown that there are methods to incorporate, or otherwise address, existing timber pin piles into the corrugation of the replacement vinyl seawalls to meet the Town Code's maximum projection width of 12 inches. The practice of maintaining existing pin piles and minimizing waterward projections to be no more than 12 inches into the waterway has been confirmed by an outside expert opinion (summarized below and attached). Staff's Change Order request approval of March 6, 2024, therefore included a Condition of Approval, on the permit, and the Permit Card (which is provided and displayed at the job site), that the new corrugated seawall not protrude more than 12 inches seaward of the existing seawall. The Condition of Approval allowed for construction of the new corrugated seawall to be accomplished, at 582 Ranger Lane, by working around and incorporating existing timber pin piles. Note: None of the above-described review included any construction activity at the 592 Ranger Lane property.

At all times Town Staff reviewed an application relating to 582 Ranger Lane and cross-referenced applicable Town Code width requirements with the expectation that the Contractor<sup>3</sup> was designing the project in accordance with Town Code. If the plans received at the time of submittal, or as part of the requested Change Orders, depicted dimensions of 27.25 inches for the 582 Ranger Lane seawall replacement, as was provided as a supplemental AFTER-THE-FACT submittal on May 10, 2024, staff would have denied the building permit or any subsequent change orders. The Contractor clearly had the ability to produce such a dimensioned drawing but failed to provide those details to the Town.

Importantly, the Departure request and building permit application for 592 Ranger Lane did not indicate that timber pin piles were located along the 32-inch section of seawall constructed. The Departure request also did not include information supporting the claim that, if there were timber pin piles, that they could not be removed without possibly endangering upland structures or features.

The application materials for the 592 Ranger Lane property also did not indicate that the new corrugated seawall could not be constructed around the existing timber pin piles (if there were existing timber pin piles) within the maximum Town Code required 12 inches.

---

<sup>3</sup> The contractor indicates that it has permitted seawall projects in the Town for 25 years.

Staff received a Professional Opinion (Attachment B) from Wood Dock and Seawall indicating that replacement seawalls are, and can be, constructed around pre-existing timber pin piles to not protrude more than 12 inches. There are multiple ways that such construction can be accomplished. According Wood Dock and Seawall, timber pin piles are typically spaced between 3 to 6 feet apart, depending on the height and condition of the seawall. The corrugated replacement seawall has corrugation of approximately 9 inches. The replacement corrugated seawall can be constructed around timber pin piles incorporating them into the indentions of the corrugated vinyl installation as opposed to placing the seawall on the outward side of the timber pin piles. In locations where the corrugation may not line up with the location of a timber pin pile, the applicable timber pin pile can be removed or relocated as each corrugated section panel is added immediately adjacent (within the corrugated notches) to the face of the existing seawall. Such removal or relocation can be supported jacks and tie-backs as each individual corrugated sheet panel is installed.

It is the responsibility of all property owners and contractors under the Florida Building Code and Town Code to obtain a permit for any shoreline construction. Verbal communications between Town Staff and the property owners for 592 Ranger Lane indicate that the 592 Ranger Lane property owners initially had knowledge and consented to the seawall replacement work being extended from 582 Ranger Lane onto their property to fill in a "gap" between the pre-existing seawall. However, based upon conversations with the 592 Ranger Lane property owners, once construction was underway, the 592 Ranger Lane property owners did not anticipate the width or size of such replacement work which lead the (592 Ranger Lane) property owners to initiate a complaint to the Town about the seawall construction on May 26, 2024. A building permit for a seawall for 592 Ranger Lane was not received by the Town's Planning & Zoning Department until June 30, 2024.

It is the responsibility of the property owner's agent (engineer, contractor, etc.) to submit complete and accurate plans of all structures during the permitting process, and to design and construct improvements based upon applicable Town and Florida Building Code requirements. Additionally, it is also the responsibility of the property owner's agents to meet all Conditions of Approval. If the Contractor was unable to construct the replacement corrugated seawall within the Town Code maximum projection of 12 inches, and per the Condition of Approval restating this Town Code requirement, it was the Contractor's responsibility to seek clarification or to request a Departure from relevant standards in the Shoreline Construction Chapter of Town Code. A Departure request was not received until June 28, 2024, after the unpermitted construction had substantially been completed (and prior to the submission of a building permit application for the 32-inch section of seawall constructed, without a building permit, at the 592 Ranger Lane property).

The constructed dimension of the new corrugated seawall on the 592 Ranger Lane property, at 27.25 inches from the existing seawall, is in excess of dimensions allowed without a permit from the Florida Department of Environmental Protection (FDEP). Florida Administrative Code (62-330.051, Exempt Activities) provides that seawalls are exempt from FDEP permitting if the new seawall extends out no greater than 18 inches. Federal approval from the Army Corps of Engineers would also be needed and cannot be provided by FDEP. Neither of these approvals were sought for 592 Ranger Lane. Both agencies have been notified of this non-compliant construction.



**Staff Conclusion**

Based on the building permit record and the above analysis, staff does not approve the Departure request for the seawall construction at 592 Ranger Lane.

You have the right to appeal my decision to the Town's Commission pursuant to Town Code Section 151.07, which is attached for your reference. Please note the petition to the Town Commission for review, must be submitted within 30 days of the date of this determination letter. Costs associated with such a request will be the responsibility of your clients.

Please contact our office if you have any questions.

Sincerely,



Allen Parsons, Director  
Planning, Zoning and Building Department  
Town of Longboat Key

Cc: Howard Tipton, Town Manager  
Maggie Mooney, Town Attorney

**Attachments**

- A. Longboat Key Code of Ordinances Section 151.07
- B. Wood Dock and Seawall Professional Opinion

---

### **151.07 Appeal.**

Any person who is aggrieved by the determination of the town manager or designee to grant or deny a permit, shall within 30 days petition the town commission for review. The petition shall briefly set forth the grounds for review. The town commission's factual review shall be limited to the information before the town manager when the decision on the application was made. The town commission shall approve, approve with conditions, or deny the petition. In making its determination, the town commission shall consider the provisions of all applicable town codes (including this Code), state and federal law.

(Ord. 07-28, passed 7-9-07)

# Wood Dock & Seawall

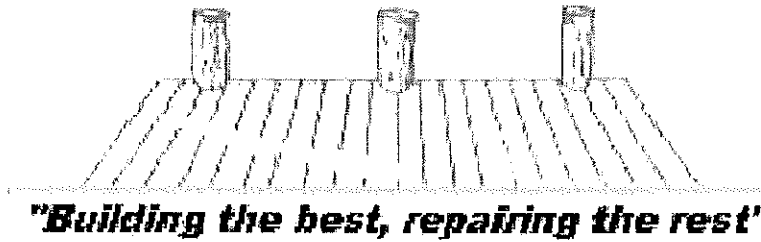

P.O.BOX 489 CORTEZ, FL 34215 PHONE (941-792-5322)

08-14-24 Rev.

Re: Seawall questions

Dear Town of Longboat Key,

1. Wood Dock and Seawall has 38 years' experience in marine construction in Florida Manatee and Sarasota counties  
State certified marine contractor license SCC131150964  
State certified Residential contractor license CRC049564
2. Brace or pilings pins can be wood or concrete, and by definition of LBK are considered a buttress.
  - A. Pilings varying in length dependent on the height of the seawall.
  - B. They have been used since we've been in business, but not so much since the inception of sheet pilings.
  - C. They are used to help prolong and stabilize an existing seawall.
    - Sheet piling is permanent new seawall and brace pin is shoring up a wall to buy time for replacement.
    - Brace pins were used to help an old wall from falling and is a lot cheaper than a new sheet pile wall.
3. Pin piles were installed mainly by water jet against the face of seawall with spacing between 3'-6' and depending on height and condition of seawall.
4. Seawall could be constructed in the instance where bracing pins were previously installed, (not protruding more than 12 inches seaward of the existing seawall or seawall cap). You would need to remove/relocate the brace pins as you install the sheet pile adjacent to face of exiting seawall panels. Install the bolts, jacks and tie backs as you proceed to install the sheet pile.

5. As stated above, the order of operations is important. Also, you can install additional bracing on the water side of seawall jacks. You can also excavate behind wall to relieve some pressure if there is room.
  - I can't expand on this / Methodology may vary by existing walls condition.
  - Seawall jacks are the brackets that support the floor of new seawall cap.
  
6. Distance and spacing of tie backs is site specific depending on the seawall exposure and upland surcharges. Spanner beams may need to be implemented if a pool is very close or other amenities.
  - Taller walls and close proximity of structures and grade may require tie back spacing closer.
  
7. Sample pictures attached.

FLOORING JACKS / CAP SUPPORT BARACKETS

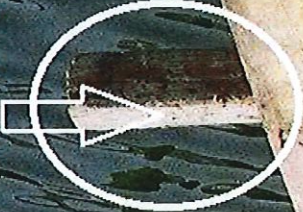

NEW MANTA RAYS  
INSTALLED AS  
SHEET PILE WAS  
INSTALLED PRIOR  
TO CAP FOUR



EXISTING TIE BACKS TO  
REMAIN FOR SEAWALL  
SUPPORT DURING  
CONSTRUCTION



4:30:03

## Attachment 'E'



**PERSSON, COHEN, MOONEY, FERNANDEZ & JACKSON, P.A.**  
ATTORNEYS AND COUNSELORS AT LAW

David P. Persson\*\*

Andrew H. Cohen

Kelly M. Fernandez\*

Maggie D. Mooney\*

R. David Jackson\*

Daniel P. Lewis

Amy T. Farrington

\* Board Certified City, County and Local Government Law

\*\* Retired

Telephone (941) 306-4730

Facsimile (941) 306-4832

Email: mmooney@flgovlaw.com

Reply to: Lakewood Ranch

MEMORANDUM

TO: Howard N. Tipton, Town Manager  
Allen Parsons, Director Planning, Zoning and Building

FROM: Maggie Mooney, Town Attorney  
Amy Farrington, Esq.

DATE: September 18, 2024

RE: Equitable Estoppel Principles in Land Use /Permitting Matters

The purpose of this Memorandum is to provide the Planning, Zoning and Building Department guidance on equitable estoppel principles and the ability of that argument to be raised by property owners. Florida courts have used the concepts of vested rights and equitable estoppel interchangeably in determining property rights cases. Vested right is a legal concept where a property owner is able to rely on regulations in existence at the time of permitting and construction. The doctrine of equitable estoppel is based on the “rules of fair play.”<sup>1</sup> A property owner can claim equitable estoppel against the local government to stop the government from imposing new regulations or changing a prior decision. Equitable estoppel is an affirmative defense meaning that it is raised by a property owner to avoid liability or provides a basis to prevent a strict application of law.

---

<sup>1</sup> *Castro v. Miami-Dade County Code Enforcement*, 967 So.2d 230, 234 (Fla. 3<sup>rd</sup> DCA 2007).

To prevail on an equitable estoppel argument, the burden is on the property owner to affirmatively establish the following three central elements:

1. The property owner acted in good faith;
2. Upon an act or omission of the government; and
3. Has made a substantial change in position or incurred extensive obligations and expenses that it would be inequitable and unjust to take that acquired right.<sup>2</sup>

In addition to the above elements, a party seeking to invoke estoppel against a government must also establish affirmative government conduct going beyond mere negligence.<sup>3</sup> However, affirmative government conduct does not necessarily have to “prove intentional deceit” by the government either.<sup>4</sup> Further, the doctrine of equitable estoppel is infrequently applied against the government and “only in rare instances and under exceptional circumstances.”<sup>5</sup>

### **Ignorance of the Applicable Law is Not Grounds for Estoppel**

The caselaw evaluating whether or not property owners should be held to strict municipal codes indicates that property owners (and their agents) are on constructive notice of the applicable regulations in effect at the time of application. See, *Town of Lauderdale-By-The-Sea v. Meretsky*, 773 So.2d 1245 (Fla. 4<sup>th</sup> DCA 2000) (finding that the municipality was not estopped from requiring the removal of a newly constructed wall located on the public right of way because the property owners were on constructive notice of the contents of the ordinance had constructive knowledge of the permit process); see also, *City of Delray Beach vs. DeLeonibus*, 379 So.3d 1177 (Fla. 4<sup>th</sup> DCA 2024) (denying property owner estoppel arguments and finding that property owners are on constructive notice of the legal obligations and procedural processes in city code regarding their property when the homeowners received building official approval for a rooftop terrace that exceeded the (then) height limitation without the prior approval by a review board). Courts have repeatedly found that estoppel arguments are not applicable when property owners fail to follow city land use procedures because property owners are legally obligated to examine the public records of the zoning authority and are on “constructive notice of the ordinances, resolutions, and filed plans and restrictions governing a parcel of property.”<sup>6</sup>

### **Legal Reliance Is Dependent Upon An Actual Right**

Principles of legal reliance by a property owner are contingent upon the property owner having a right to rely on a government action.<sup>7</sup> A permit obtained in violation of an ordinance or other legal requirement does not support an equitable estoppel argument. The issuance of a building permit does not eliminate the government’s authority from enforcing its ordinances and revoking a permit

---

<sup>2</sup> *The Hollywood Beach Hotel Company v. City of Hollywood*, 329 So.2d 10 (Fla. 1976).

<sup>3</sup> *Alachua County v. Cheshire*, 603 So.2d 1334 (Fla. 1<sup>st</sup> DCA 1992).

<sup>4</sup> *Id.* at 1337.

<sup>5</sup> *Calusa Golf, Inc. v. Dade County*, 426 So.2d 1165, 1167 (Fla. 3<sup>rd</sup> DCA 1983).

<sup>6</sup> *Delray* at 1181 (citing *Palm Beach Polo, Inc. v. Village of Wellington*, 918 So.2d 988, 992-993 (Fla. 4<sup>th</sup> DCA 2006)).

<sup>7</sup> See *Calusa Golf*.



which has been obtained in violation of its laws.<sup>8</sup> Generally, a “building permit issued in violation of law or under mistake of fact may be rescinded although construction may have commenced.”<sup>9</sup>

In *Town of Lauderdale-By-The-Sea*, the property owners applied for, and received a building permit, based on an inaccurate application that failed to include all relevant information pertaining to the construction. Upon the discovery that the construction was on the right-of-way and not in compliance with the city ordinances, the city delivered a cease-and-desist order. The property owners completed the construction against the order. The Fourth DCA held that the city could not authorize an act that was against its own ordinances (e.g., approving a building permit over a right-of-way).

In *Dade County v. Gayer*, homeowners applied for a permit after a wall was partially constructed. The application contained a setback of ten feet inside the property line. After approval of the permit, construction exceeded the authorized setback allowance and entered into the right-of-way, which was not in accordance with the permit. Homeowners applied for, and received, a variance recommendation that was ultimately denied by the County Commission. The Third DCA upheld the variance denial and ordered the remove the wall finding that “it would be inconceivable that public officials could issue a permit, either inadvertently, through error, or intentionally, by design, which would sanction a violation of an ordinance adopted by the legislative branch of the government.”<sup>10</sup>

### **Inaccurate/False Permit Information Negates Estoppel Principles**

In many of cases evaluating estoppel arguments raised by property owners, a permit was deemed illegally issued due to an inaccurate permit application or incorrect information about the project. These types of issues resulted in determinations by the courts that the permits were issued for projects that were in violation of existing ordinances, thereby causing the permit itself to be determined to be illegal.

In *Dade County vs. Bengis Associates*, the court held that the County was not estopped from requiring the removal of a sign that was approved and installed based on incorrect zoning information provided by the applicant in the permit. The size of the sign was too large based on actual zoning requirements and the court held that the city “is not estopped from the enforcement of its ordinances by an illegally issued permit which is issued as a result of mutual mistake of fact.”<sup>11</sup>

Even if construction has already commenced, a building permit issued under mistake of fact may be rescinded.<sup>12</sup> In *Godson vs. Town of Surfside*, the size of the property diminished due to changes in the shoreline, which impacted the buildable area on the lot. The Florida Supreme Court found that the owner knew that the facts in the permit application were accepted as true and that any deviation would result in a permit revocation. Ultimately, the city was not estopped from rescinding

---

<sup>8</sup> *Town of Lauderdale-By-The-Sea* at 1248.

<sup>9</sup> *Id.* (citing *Godson v. Town of Surfside*, 150 Fla. 614, 8 So.2d 497, 498 (1942)).

<sup>10</sup> *Dade County v. Gayer*, 388 So.2d 1292, 1294 (Fla. 3<sup>rd</sup> DCA 1980).

<sup>11</sup> *Dade County v. Bengis and Associates, Inc.*, 257 So.2d 291, 292 (Fla. 3<sup>rd</sup> DCA 1972).

<sup>12</sup> *Godson vs. Town of Surfside*, 150 Fla. 614 (1942).

the permit due to the fact that the continued building would “result in a violation of one of the city ordinances which it was their duty to enforce.”<sup>13</sup>

In *Meretsky*, the city issued a cease-and-desist ordering work to stop on a wall that was encroaching on the right of way. The permit application did not refer to the right of way and discussion was limited to setbacks (the survey map indicated a side lot encroachment onto the right of way). The court held that “whether through mistake on the part of the parties or through misrepresentation” by the property owners the approval of the permit based on inaccurate information was against the city’s ordinances and the city was not estopped from revoking the permit.<sup>14</sup>

Based upon the above, it is important for the Town to understand that the property owners assertions of equitable estoppel are difficult to prove particularly when applicable zoning, land use and permitting requirements are ignored and/or violated by property owners or their representatives. Even if elements of equitable estoppel are met, misrepresentations (intentional or unintentional) generally diminish property owners’ estoppel assertions. Nevertheless, we would encourage Town Staff to notify property owners of discovered violations of applicable codes and permitting requirements found during construction processes at the earliest opportunity available so that property owners can correct and mitigate the issue at the earliest opportunity. We hope that the principles summarized above provide guidance should assertions of equitable estoppel present themselves in the Planning, Zoning and Building Department. Should you have any questions or concerns regarding this Memorandum, please do not hesitate to contact us.

---

<sup>13</sup> *Id.* at 619.

<sup>14</sup> *Meretsky* at 1249.

# Attachment 'F'



# LAW OFFICE OF ROBERT K. LINCOLN, P.A.

LAND USE AND LOCAL GOVERNMENT LAW AND LITIGATION

1517 STATE STREET, SUITE 203, SARASOTA, FL 34236 | 941. 681-8700 | WWW.FLALANDLAW.COM

July 19, 2024

*Delivered via Email: [aparsons@longboatkey.org](mailto:aparsons@longboatkey.org)*

Allen Parsons, Director, Planning, Zoning & Building Department  
Town of Longboat Key  
501 Bay Isles Road  
Longboat Key, FL 34228

RE: Country Club Association, Inc.'s Objection to Departure Application PAR24-001 for Seawall Construction at 582 Ranger Lane,

Dear Mr. Parsons:

As you know, I represent Country Club Association, Inc. (the "Association") regarding its concerns with Application #PAR24-001 (the "Application"), a request for a Departure for Seawall Construction for property located at 582 Ranger Lane (the "Property"). The Application also seeks after-the-fact permission to depart from the seawall construction standards at 592 Ranger Lane (the "Adjacent Property"). I write to state the Association's concerns and objections to the Application and urge the Town to deny the Departure.

## History

The Applicant applied for the seawall permit on March 22, 2023, but did not submit engineered plans until February 12, 2024. Those plans failed to account for the "timber pins" later found to be supporting the existing seawall. On April 11, 2024, the Applicant submitted revised plans (the "Revised Application"). The Revised Application was misleading, incomplete and failed to comply with the Town Code. Regardless, the Town approved the Revised Application and issued building permit PB23-0253 (the "Permit").

However, when the Town inspected the construction on or about May 7-8, 2024, the inspector discovered that the construction violated the Permit and Sec. 151.03(B)(3)(a) of the Town Code because the face and cap of the newly installed seawall extended more than 12" beyond the adjacent seawall. The inspector issued a stop-work order.

The construction of the seawall was in blatant violation of the plain requirements of the Code, not only with respect to the location of the seawall on the Property, but also with respect to its extension beyond the face of the existing seawall and seawall cap on the Adjacent Property. In addition, the Applicant (or its agents) simply extended the seawall construction onto the Adjacent Property without a permit and also in violation of the standards – another blatant violation that resulted in a separate Code Enforcement action against the Adjacent Property, and also required the Adjacent Property to be included in the Application.

On May 11, 2024, the Applicant submitted additional drawings asking the Town to approve the permit despite the clear violation of the Code. For the first time, the Applicant attempted to justify installing the seawall beyond the timber pins based on alleged (but unsupported) risks to the environment and existing pool. When the Town refused, the Applicant filed the Application, which now seeks to both waive the clear requirements of the Code and excuse blatant violations of the Code.



ROBERT K. LINCOLN | Board Certified in City, County and Local Government Law | [Robert.Lincoln@flalandlaw.com](mailto:Robert.Lincoln@flalandlaw.com)  
STACY DILLARD-SPAHN | Managing Attorney | [Stacy.Dillard@flalandlaw.com](mailto:Stacy.Dillard@flalandlaw.com)

### Key Facts

The Applicant's Building Permit application includes the following statement:

**Applicant's Affidavit:** I certify that all the information is accurate and complete. *I further certify that* no work or installation has commenced prior to the issuance of a permit and *that all work will be performed in accordance with the standards of all laws regulating construction in this jurisdiction.*

(emphasis added).

The Transmittal narrative filed with the Revised Application failed to indicate that the entire seawall was being moved further seaward. In fact, the "description" stated:

Revisions to plans: *everything to stay the same with the only exception* being that we are widening the cap by 8" which will take the original plans from a 28" wide cap to a 36" wide cap.

(emphasis added). That statement was not true: the Revised Application also moved the proposed seawall beyond "timber pins" that had previously been installed outside the seawall.

Page 1 of the Revised Application drawing included a text box stating:

EXISTING TIMBER PIN PILES TO REMAIN. PROPOSED WALL TO BE INSTALLED DIRECTLY IN FRONT OF PIN PILES.

Page 2 of the Revised Application includes a cross section locating the proposed seawall beyond "Existing Timber Pin Piles to Remain". *Moreover, the cross-section drawing depicts the face of the new seawall at 12" beyond the "Pin Piles" and the new seawall cap to extend an additional 6" beyond the face of the new seawall, for a total of 18"*.

In addition, the Revised Application drawing on Page 1– as in the original – depicts the proposed seawall as almost aligned with the existing adjacent seawalls.

The Revised Application did not directly request the Town: (1) to agree that the "Pin Piles" were or should be treated as the face of the seawall or seawall cap (as the Applicant now asserts), (2) to agree that the proposed seawall and cap could be 18" wide rather than 12", or (3) to agree that the proposed seawall and cap could extend more than 12" beyond the seawall of the Adjacent Property or the property to the west. If such a request had been made, the Town would have (or should have) responded that each of those requests are separate and distinct departures from the plain requirements of the Town Code.

The Permit Comment and Corrections Report, issued on April 19, 2024, based on a review of the Revised Application, states:

This is the summary of the review comments from the applicable disciplines of plans received. This review summary shall not be construed as authority to violate, cancel, alter or set aside any provision of the Town Codes or Ordinances. Please submit revised drawings/plans per the comments below.

The Town then issued the Permit on April 20, 2024, based on the misleading Revised Application. The Permit includes the following express stipulation (taken from Sec. 151.03(B)(3)(a)):

Construction, inclusive of a buttress and seawall cap, shall not protrude more than 12 inches seaward of the existing seawall or seawall cap. Notwithstanding the foregoing, if there are two existing seawalls abutting the subject replacement seawall of differing seaward projections, then the subject replacement seawall shall be further limited to a seaward projection distance of no more than either equal to the immediately abutting seawall with the least projection or a total seaward projection of 12 inches, whichever is less.

The “aerial surveys” submitted as part of the original permit application and included in the Application demonstrate that, prior to the new construction, the face of the seawall cap on the Property was in-line (within inches) from the face of the seawall caps on the Adjacent Property (which lies to the east) and at 572 Ranger Lane, which lies to the west of the Property. See, e.g. Application, Pages 6-7.

The Sampey Burchett survey sealed and dated July 22, 2021 (submitted on May 10, 2024) also depicts the seawalls and caps on the neighboring properties as functionally extending from the face of the seawall cap on the Property. In addition, the Sampey Burchett survey depicts the pool located 17.7’ from the back of the seawall cap, with a deck that runs to a point 13.0’ from the seawall. However, the “disapproved” “Sketch” submitted on May 10, 2024 - and included at Page 13 of the Application - depicts the pool shell a mere 10’ from the existing seawall.

The minimum canal setback in the applicable R-4SF zone district is 20’. Pursuant to Zoning Code Sec. 158.094(C)(4), regulating canal yards, “[t]he waterfront yard is a required yard and shall not be utilized for any purpose other than docks, open area, landscaping, a dock access ramp or stairs, a ladder or other device pursuant to Subsection 158.096(F)(2)...” However, per Sec. 158.095(B)(1), in a single-family district, the waterfront yard setback for a swimming pool of less than 6” above finished grade, without a cage, is 15’. The picture at Page 17 of the Application appears to depict the pool shell at greater than 6” above grade, which would require locating it 20’ from the property line.

In addition, the Applicant never submitted the Permit to the Association for review and approval, as expressly required by the Declaration of Covenants applicable to the Property. While the Town does not and cannot enforce those covenants, if the Applicant had complied and submitted the plans and permit to the Association prior to commencing construction, the issue might have been identified and addressed before the Applicant constructed an illegal structure. Responsibility for that failure lies with the Applicant, not with the Association, the other lot owners represented by the Association, or the Town.

### **The Permit Application and Revised Application Never Met the Requirements of the Code.**

The Permit Application never met the application requirements of Sec. 151.03(B)(1)(c) because the plans failed to include accurate drawings or depictions of the existing adjacent seawalls within 200 feet – an omission which directly led to the current problem.

The proposed seawall and cap *never* met the standards of Sec. 151.03(B)(3)(a), which limits the total distance for a replacement seawall *and cap* to 12” from the face of the existing seawall and seawall cap. Even a cursory review of the cross-section diagram on Page 2 of both the initial engineering plans and the “approved” April 12 plans, show the face of the “new” seawall at 12” from the existing seawall – or in the case of the April plans, the “pins” – *plus* an additional 6” from the face of the seawall to the face of the cap, for a total of 18”. The Application drawings also depict the improper extension. See Application Page 9. If granted, the Departure

would approve this additional 6” incursion into the canal that was *never* intended or permitted by the Code, and never expressly requested as a Departure.

**The Town Should Not Grant a Departure Based on the Erroneous Approval of the Permit.**

The Applicant attempts to place the burden of its illegal construction of the seawall on the Town’s Permit approval, claiming “notwithstanding there is a condition noted on the permit requiring compliance with Section 153.B.3.a, (sic) the contractor assumed that the construction pursuant to the approved permit was in all ways compliant.”

Above and beyond the language on the Permit itself, the contractor could not have believed in good faith that the new seawall was compliant with the Code and the Permit. First, it was clear that the proposed seawall and cap extend more than 12” beyond the prior seawall and cap – even if the “Timber Pins” could be included. It was also clear to the contractor that the new seawall would extend more than 12” beyond the face or cap of the adjacent seawalls. And, it was certainly clear to the contractor that the Permit did not authorize construction on the Adjacent Property.

The Town’s permit reviewers rely on the Applicant (or its engineer or contractor) having reviewed sealed drawing submitted with an application for compliance with the Codes. While the reviewers may catch errors, in this case the Applicant submitted incomplete and misleading drawings and narrative for the Revised Application, which likely led the reviewer into overlooking the Applicant’s changes to the location of the proposed seawall. The Applicant has no right to imply the Town is responsible for not “catching” these violations, and the Town should not grant a departure to solve a problem created entirely by the Applicant and its agents.

Ultimately, it appears the Applicant and his agents “pulled a fast one” on the Town in this case by providing misleading information and incomplete plans that fail to comply with the Code. The contractor (and the Applicant) cannot complain about the Town catching these violations during inspection and cannot assert any good-faith reliance on the Town’s issuance of the Permit. The Applicant (and its agents) are wholly responsible for a situation that could have been avoided if they had simply followed the Code and the Association’s covenants. Any burden on the Applicant to now comply with the Code is legally insufficient to serve as justification for a departure.

**The Town Must Deny This After-the Fact Departure Request  
For a New Seawall and Cap That Directly Violates the Town Code.**

Both the original plans and the Revised Application propose construction of a seawall and cap that extends 18”, rather than 12”. The Plans fail to meet the unambiguous 12” limit on replacement seawalls established by Sec. 151.03(B)(3)(a). Regardless of whether the Applicant should be allowed a separate departure to build beyond the “Timber Pins”, or extend past the adjacent seawalls, the Town must deny a departure for a seawall that does not even attempt to meet the Code’s 12” limit for replacement seawalls and caps.

If the Applicant and its agents thought the Code’s 12” standard was somehow unreasonable or unworkable for this site, it was their responsibility to request a departure from that standard *during the application process and before construction*. The Town must not allow the Applicant to abuse the departure process by submitting a non-compliant application and then requesting an after-the-fact departure to avoid the clear legal standards.

**The Town Should Deny the Departure Because the Applicant Could Have Met the Codes, and the Current State of the Seawall and Pool Do Not Legally Justify a Departure.**

The Applicant attempts to justify construction beyond the face of the “Timber Pins” - rather than the face of the existing seawall and cap - by claiming that the existing seawall may collapse if the pins are removed, possibly resulting in environmental damage and damage to the pool and deck. However, the Applicant and contractor have other options to meet the Code rather than coopting an additional 15” (or more) of the canal. The Applicant could shore the seawall with smaller “pins” and remove the existing pin piles, construct the new seawall *behind* the existing seawall, provide sediment screens in the canal behind the construction, and utilize other methods to comply with the Code. Based on the aggravating factors present here, the Town should deny this request for an after-the fact departure for construction beyond the actual face of the existing seawall and cap.

**Conclusion**

Town Code Section 151.03(E) requires the town manager to “determine that the proposed design meets the intent of this chapter” before granting a departure. Section 151.02 states, in relevant part, that the purpose of the chapter is to manage and conserve the town’s shoreline by “regulating the installation of seawalls ... to ensure the minimal physical effect on existing shoreline conditions...” Here, the proposed seawall violates the Code by extending more than 12” past the existing seawall and cap, not only on the Adjacent Property, but in front of the existing seawall - and in fact, in front of the existing timber pins.

The Application is wholly inconsistent with the purpose and intent of the Code to regulate the installation of seawalls when considering the actions of the Applicant and its agents. As demonstrated above, the Applicant (and its contractor or engineer): (1) filed plans that never met the Code standard for replacement seawalls (requesting 18” rather than 12”); (2) filed a misleading narrative with the Revised Application that did not disclose the fact that the seawall was being moved; (3) filed incomplete and misleading plans that did not properly depict the configuration of the proposed construction with respect to the neighboring seawalls; and (4) commenced construction on the Adjacent Property without a permit. In addition, the Applicant has never properly or fully justified why, in this case, the “pin piles” should be considered the “face of the seawall and cap” as referenced in the Code.

The Town must deny this after-the-fact Departure as a clear attempt to clean up the Applicant’s own preventable violations of the Town Code. On behalf of the Association, I request you include this letter in any record for this matter, including any appeal to the Town Commission.

Regards,

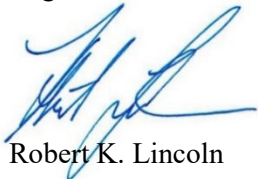

Robert K. Lincoln

RKL/adr

cc: Tate Taylor, Planner, ttaylor@longboatkey.org  
Maggie Mooney, Town Attorney, mmooney@flgovlaw.com  
Lynn Larsen, President, Country Club Association, Inc.  
Jim Essenson, Esq, General Counsel, Country Club Association, Inc., jessenson@essenson.law.com



**End of Agenda Item**